

IDENC

DAB/DAB+ Audio Encoder

User's manual



Author	F.Berti
Version	3.0.0 - 21/11/2024
Copyright	© 2024 ITEL SNC

Table of contents

Section 1 Introduction	4
1 Revisions	4
2 Warnings	6
3 Front Panel	7
4 Rear Panel	8
5 GPIO connector	9
Section 2 Configuration	12
1 Start Up	13
2 Login	13
3 Edit And Save Parameters	13
4 Encoders	15
Encoders Configuration	16
Pad configuration	20
5 DSP	22
6 Announcements	27
7 Networking	29
8 Alarms	31
9 Snmp	33
10 Maintenance	35
11 System	37
12 Log	38
Section 3 Recovery	40
1 Menu and factory reset	40

Section

Introduction

1

1 Introduction

The system is supplied in a steel case, the front shows the status of the machine, the rear contains all the connectors including the Gigabit LAN interfaces through which it can be connected to the multiplexers, to the internet as well as to be administered via integrated web server.

The machine integrates a DAB + encoding system that allows you to capture audio from streaming sources or analog and digital audio inputs, encode it according to the DAB or DAB + standard, add SLS and DLS into the PAD (program associated data), then create the stream TCP ready to be transferred to the multiplexers.

The encoder contains patented software parts and Digital Audio Broadcasting technology released under license from Fraunhofer IIS to ITEL, it contains also audio processing library property of ITEL, any violation, attempt of extraction or attempt to reverse engineering on software and hardware parts is sanctioned and prosecuted even criminally according to the relevant legislation in the countries of ITEL and Fraunhofer IIS.

<http://www.iis.fraunhofer.de/audio>

The configuration interface that will be presented below allows the encoder to start up in a few steps.

It is advisable to place the system in an air-conditioned and dust-free environment, the temperature range in which the server guarantees perfect and continuous operation is 5 ° C / 35 ° C.

1.1 Revisions

1.1.0	10/09/2017	First edition
1.2.0	01/11/2018	Second edition
1.3.0	01/03/2019	Third edition
1.4.0	20/02/2020	Fourth edition
1.5.0	15/07/2020	Fifth edition
1.6.0	23/11/2020	Sixth edition
1.7.0	24/05/2021	Seventh edition
2.0.0	28/10/2021	Eighth edition
2.1.0	27/01/2022	Ninth edition
2.2.0	25/07/2022	Tenth edition
2.2.1	29/11/2022	Eleventh edition
3.0.0	22/02/2023	Twelfth edition

1.2 Warnings



Before carrying out any operation, follow the safety rules contained in the following paragraph.

The manufacturer declines all responsibility in case of damage to persons or things due to non-observance, even partial, of the following indications

- Make sure that the supply voltage corresponds to what is reported on the appliance.
- Check that the electrical system is equipped with an earth socket
- Use only earthed sockets
- Disconnect the power supply before carrying out any operation inside the appliance.
- The device for disconnecting the device is the power cable, so this must be easily accessible and the socket must be placed near the device itself.
- Any operation that entails access to the internal parts of the equipment must be completed, after disconnection of this from the electrical network, exclusively by qualified technical personnel.







1.3 Front Panel

Front view



Key switch and Leds on front panel



-  Power switch: If pressed more than 3 seconds the device shut-down
-  Reset switch: Reboot system
-  Red led: Drive activity
-  Yellow led: Lan activity
-  Green Led: Power ON
-  Usb 2.0 Ports

1.4 Rear Panel

Rear view



Rear connectors

- AC IN Power connector 100-240VAC 50-60Hz
- PS/2 Only for [Recovery](#) function
- ETH Ethernet connector RJ45
- USB Only for [Recovery](#) function
- USB 3.0 Not used
- HDMI Only for [Recovery](#) function
- COM1 Reserved for future feature
- VGA Only for [Recovery](#) function
- AUDIO INPUT 1/2 Audio input connector with supplied cable DB9-M -> XLR-F
- GPIO Remote control connector DB15-F

Audio Input connector

The audio inputs are connected via the cable supplied with standard female XLR connectors, on the rear panel there are two 9-pole DSUB female connector with the following connection arrangement:

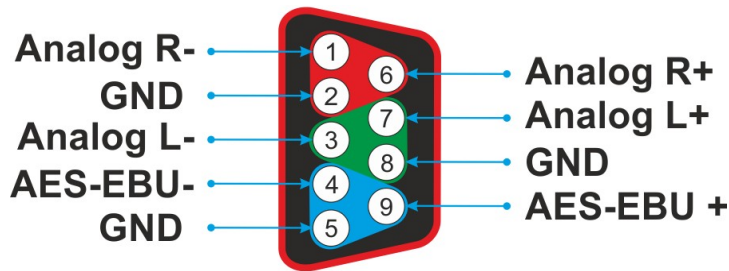

PIN	Description
1	Analog input Right -
2	GND
3	Analog input Left -
4	AES EBU / Digital input -
5	GND
6	Analog input Right+
7	Analog input Left+
8	GND
9	AES EBU / Digital input +

1.5 GPIO connector

The GPIO connector allows to monitor and control the encoder via opto-isolated inputs and outputs. The inputs consist of polarized optocouplers with 470 ohm protection resistor inserted in series. The maximum current allowed on each coupler is 20 mA. The outputs are of the solid state relay type, with reference to the EXT COMMON contact the signal can be: low impedance (CLOSE) or high impedance (OPEN), the maximum applicable current is 100mA, the typical resistance in CLOSE is 16 Ohm. The voltage supplied between pin 12 and pin 1 is +5 Vdc, with maximum permitted absorption of 200mA.

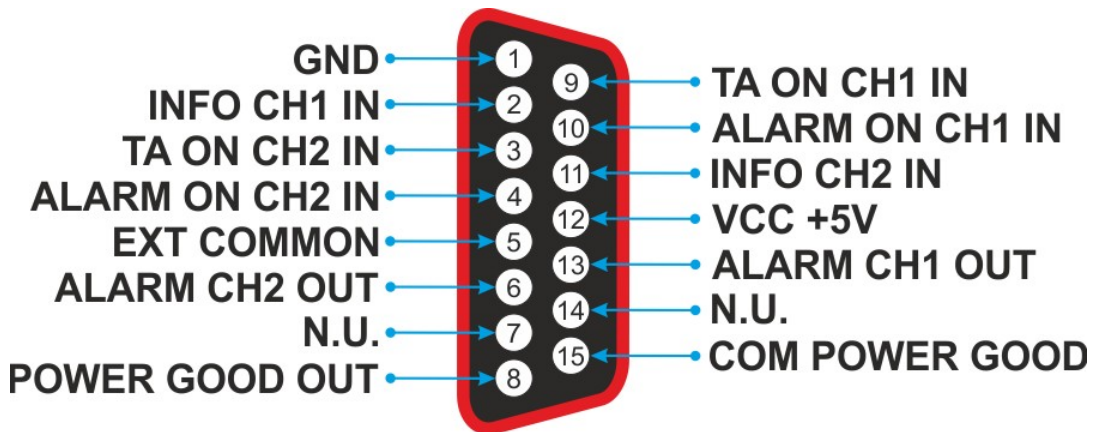

PIN		Descrizione
1	GND	GND common Ground (Chassis)
2	INFO CH1 IN	CHANNEL 1 INPUT FOR "INFO"
3	TA ON CH2 IN	CHANNEL 2 INPUT FOR "TA"
4	ALARM ON CH2 IN	CHANNEL 2 INPUT FOR "ALARM"
5	EXT COMMON	EXTERNAL COMMON FOR OUTPUT FOR PIN 6-13
6	ALARM CH2 OUT	CHANNEL 2 OUTPUT FOR "ALARM"
7	N.U.	NOT USED
8	POWER GOOD OUT	OUTPUT FOR POWER GOOD FOR PIN 15
9	TA ON CH1 IN	CHANNEL 1 INPUT FOR "TA"
10	ALARM ON CH1 IN	CHANNEL 1 INPUT FOR "ALARM"
11	INFO CH2 IN	CHANNEL 2 INPUT FOR "INFO"
12	VCC +5V	POWER SUPPLY +5VDC 200mA MAX
13	ALARM CH1 OUT	CHANNEL 1 OUTPUT FOR "ALARM"
14	N.U.	NOT USED
15	COM POWER GOOD	COMMON FOR POWER GOOD TO PIN 8

EXAMPLE SCHEME

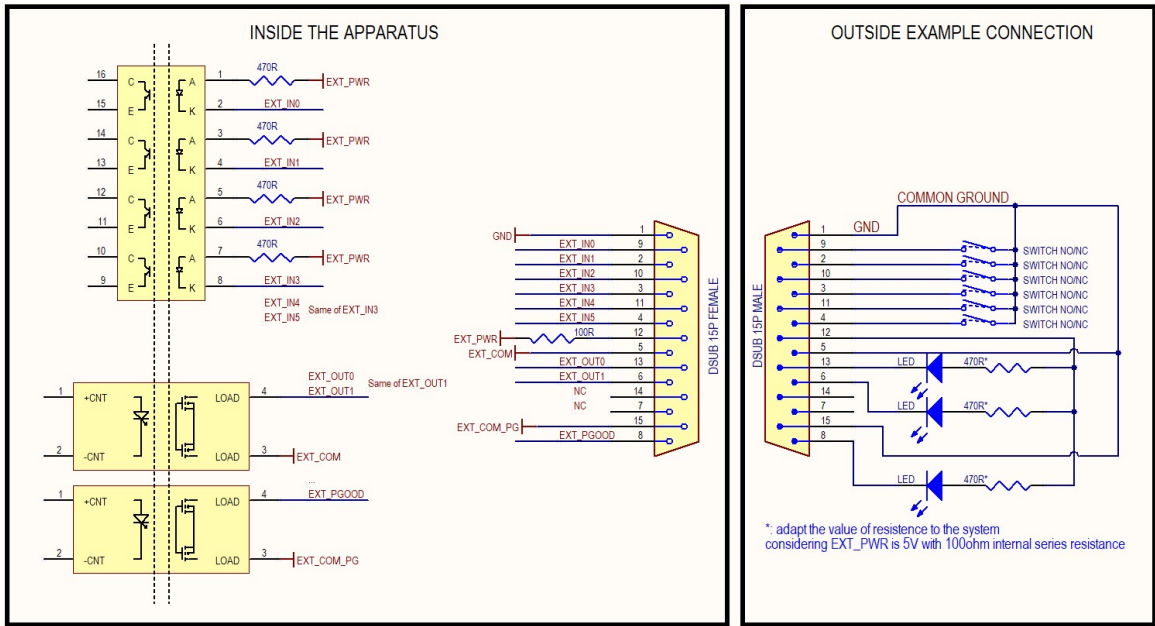

Section

Configuration

2

2 Configuration

The system configuration is completely managed by the web interface, reachable at the IP address of the device at the standard port 80.

The screenshot displays the 'DAB Encoder' web interface. The top navigation bar is blue with the 'itel' logo on the left, the title 'DAB Encoder' in the center, and a 'LOGOUT' button on the right. A vertical sidebar on the left contains ten menu items, each with a colored circular icon: ENCODERS (blue), DSP (yellow), ANNOUNCEMENTS (purple), NETWORKING (cyan), ALARMS (yellow), SNMP (green), MAINTENANCE (red), SYSTEM (grey), and LOG (white). The main content area shows two encoder configuration panels. The first panel, 'Encoder 1 - encoder1', is for 'Direct Input (Digital 1)' and features a level meter with a scale from -40 to 0 dB. The second panel, 'Encoder 2 - encoder2', is for 'Direct Input (Analog 1)' and also features a level meter with a scale from -40 to 0 dB. Both meters show a signal level around -10 dB. Each panel includes a 'PAD' button and an upward arrow icon.

2.1 Start Up

Connect the Ethernet port of the Encoder using a LAN cable to your local network, select an IP of the computer in the 192.168.0.xxx class except value 192.168.0.10, then open the browser and type 192.168.0.10, at this point the login request will be displayed.

If you want to change the IP from the [Recovery](#) menu, please read this chapter at the end of the manual.

The eth0 interface is reserved for encoder administration and for sending data to the multiplexers, the eth1 interface is reserved for receiving audio streams in AES67 format, it is important to assign the eth1 interface a network address of a different class from that of the eth0 interface.

From the networking menu it is possible to modify the network addresses of the interfaces

2.2 Login

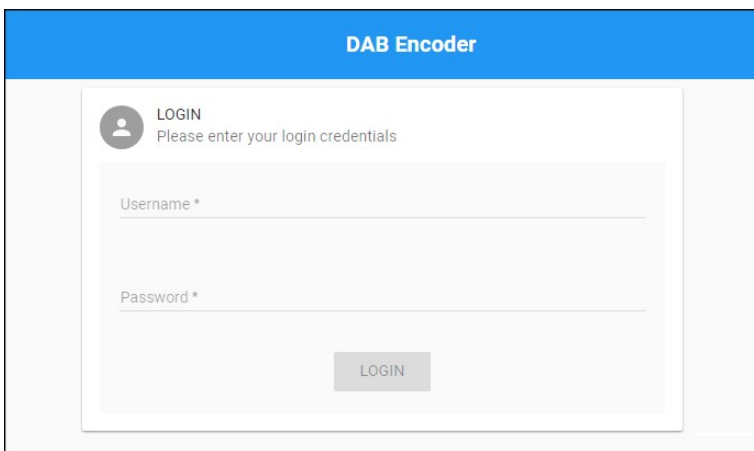

At the first start the credentials to access are:

Username: admin

Password: admin

Once inserted, click with the left mouse button on the LOGIN key, the configuration interface will shortly be loaded and we will be in the Sources section.

The configuration interface consists of a menu on the left of your screen from which you can select the various topics to edit, in the other on the right there is the button to log out in order to exit the configuration.

2.3 Edit And Save Parameters

Every time a parameter is modified at the top you will notice the message "Configuration changes detected", clicking APPLY will save as previously set, by clicking cancel it is possible to cancel the modification.



If the message above is "Configuration invalid. Please correct the errors below" will be necessary to

correct the errors in the configuration highlighted in red before proceeding. An invalid configuration is not accepted.

Configuration invalid. Please correct the errors below.

 CANCEL

2.4 Encoders



ENCODERS

In the Encoders section the coding sources are shown, depending on the license's type , one or two sources will be available, each one can encode the audio coming from the analogue, digital input or from a streaming source.



By clicking on the down arrow symbol on the right ▾ the menu opens with the parameters of the encoder, making the configuration available, once the operations have been completed, the menu can be closed by clicking the up arrow key ▲.

The icon next to the down arrow allows you to enter an additional menu to edit the SLS PAD associated with that encoder.

2.4.1 Encoders Configuration

Encoder 1 - encoder1

Direct Input (Digital 1)

PAD ^

<p>Source Enabled * Yes ▼</p> <hr/> <p>Type* Direct Input ▼</p> <hr/> <p>Audio Channels* 2 (Stereo) ▼</p> <hr/> <p>Sample Rate* 48000 ▼</p> <hr/> <p>Codec* HE-AAC v1 (DAB+) ▼</p>	<p>Encoder Label* encoder 1</p> <p>Encoder name - max 16 chars 8 / 16</p> <hr/> <p>Select Input* Digital 1 ▼</p> <hr/> <p>Reference Level (dBFS)* 0 ▼</p> <hr/> <p>Bitrate* 96 ▼</p> <hr/> <p>Codec Quality Default ▼</p>
--	---

Dest. Enabled*	Dest. Type*	IP Address*	Port*	Mux Label
Yes ▼	EDI (TCP) ▼	192.168.1.145	8003 ▼	IdMux Test 1
		IP address 13 / 15	Port (from 1 to 65535)	Label (max 32 chars) 12 / 32
Yes ▼	TCP ▼	192.168.1.100	8005 ▼	IdMux Test 2
		IP address 13 / 15	Port (from 1 to 65535)	Label (max 32 chars) 12 / 32
No ▼	TCP ▼	0.0.0.0	1 ▼	Mux Label
		IP address 7 / 15	Port (from 1 to 65535)	Label (max 32 chars) 0 / 32
No ▼	TCP ▼	0.0.0.0	1 ▼	Mux Label
		IP address 7 / 15	Port (from 1 to 65535)	Label (max 32 chars) 0 / 32
No ▼	TCP ▼	0.0.0.0	1 ▼	Mux Label
		IP address 7 / 15	Port (from 1 to 65535)	Label (max 32 chars) 0 / 32

<p>EDI TS Enabled (all EDI dest.)* No ▼</p>	<p>EDI TS Delay (all EDI dest.)* 0 ▼</p> <p>Delay in ms (from 0 to 5000)</p>
---	--

<p>UTC Offset Mode* TAI Download ▼</p>	<p>UTC Offset* 0 ▼</p> <p>UTC Offset in s (from 0 to 100)</p>
--	---

For each available source the following parameters are present:

Source enabled: allows you to activate or deactivate the selected encoder.

Encoder Label: Channel label (this label is not the name of the channel in the Multiplexer)

Type: allows you to choose the type of source between **direct input** as analogue or digital input, **internet streaming** and **AES67**:

DIRECT INPUT:

Type *	Select Input *
Direct Input	Digital 1
Audio Channels *	Reference Level (dBFS) *
2 (Stereo)	0
Sample Rate *	Bitrate *
48000	96
Codec *	Codec Quality
HE-AAC v1 (DAB+)	Default

If the **Type Direct Input** has been selected, on the right will be show:

Select input: it allows the choice between the two analog inputs Analog 1 and Analog 2 and the two digital inputs AES-EBU Digital 1 and Digital 2. If the digital input has been selected, the encoder will be able to receive an AES-EBU stream with samplerate from 32000Hz up to 192000Hz, an internal resample will adapt the input sampling frequency to the samplerate of the encoder.

If the analog input is chosen, the Reference level field will be shown, this allows you to vary the reference level of the input from -12 to + 12 dBu in steps of 1dB.

If the digital input is selected, the Reference level field will be shown below, this you to set the reference level of the AES-EBU input from 0 to -12 dBFS.

INTERNET STREAM:

Type *	Internet Stream
Audio Channels *	2 (Stereo)
Sample Rate *	Bitrate *
48000	56
Codec *	Codec Quality
HE-AAC v1 (DAB+)	High (Fraunhofer)
Stream URI *	http://192.168.1.1:8080/stream.mp3
Stream remote URL (ex.: http://192.168.1.1:8080/stream.mp3)	

If the **Type Internet Stream** is selected, the Stream URI field will be shown below, here you can put the source address of the streaming.

AES67:

Type *	AES67 Input Interface *
AES67	eth1
AES67 Multicast IP Address *	AES67 Port *
239.69.231.72	5004
Insert a valid Multicast IP address	AES67 Port (from 1 to 65535)
AES67 Input Sample Rate *	AES67 Input Bit Resolution *
48000	24
AES67 Input Channels *	AES67 Payload *
2 (Stereo)	96
	Payload length (from 0 to 127)

If the **Type AES67** is selected the following fields will be shown:

- **AES67 input interface:** allows you to select from which ethernet interface you want to receive the AES67 multicast stream.
- **AES67 Multicast IP Address:** here you must specify the multicast address from which you receive the AES67 stream..
- **AES67 input sample rate:** here you must select is the sampling frequency of the AES67 stream to be received (32, 44.1, 48, 64, 96 KHz).
- **AES67 input Bit Resolution:** here you must select the number of resolution bits of the AES67 stream to be received (16, 24 ,32 bit).
- **AES67 input channels:** here you have to choose if the AES67 stream you are receiving is mono or stereo.
- **AES67 Payload:** choice of the payload applied to the data stream, the values range is from 0 to 127, the values normally used for Livewire, Dante, etc. are 96 and 97.

Audio channels: allows you to select the number of channels, the choice is between mono and stereo, in the case of AAC-HE v2 SBR + PS encoding the use of mono is not allowed, in the case of AAC-HE v1 SBR encoding with mono audio is recommended a maximum bitrate of 64 Kbit/s, all bitrates are available for mono-coded AACLC.

Sample rate: is the choice of the sampling frequency with which the signal is coded, if we have chosen the DAB coding the available frequencies are 24KHz and 48KHz, in the case of DAB + 32KHz and 48KHz.

Bitrate: is the amount of bits per second with which the source will be coded, the choice of this parameter is conditioned by the codec type selected previously (for AAC-LC encoding possible bitrates between 16Kbit/s and 192Kbit/s, for AAC-HE v1 encoding SBR possible bitrate between 16Kbit/s and 128Kbit/s, for AAC-HE v2 code SBR + PS possible bitrate between 16Kbit/s and 96Kbit/s). In the case of DAB coding, the bitrate can vary from 32 to 256Kbit/s.

Codec: allows you to choose the encoding mode between the DAB and DAB + standard:

In case of DAB + coding it will be possible to choose between AAC-LC or AAC + low complex, or AAC-HE v1 or SBR side band replication, or AAC-HE v2 or SBR + PS side band replication + parametric stereo, in particular this last choice allows you to work with maximum bitrate of 96Kbit/s. In general the AAC-HE v2 codec is recommended for smaller bitrates equal to 72Kbit/s.

In case of DAB + coding you can find the **Codec Quality** choice, if you have Fraunhofer license enabled you can choose the High quality or standard quality codec.

In case of DAB encoding, the **Audio mode** and **Psychoacoustic model for MP3 coding** fields will be shown

Audio mode: if previously the DAB standard has been selected, the choice for MP3 encoding between: Stereo, Dual, Joint stereo and mono will be shown.

Psychoacoustic model for MP3 coding: if previously the DAB standard has been selected, the choice for the psychoacoustic model of the MP3 will be shown.

At the end of the configuration parameters of coding, we find 5 editable fields that show address and ports of the 5 different multiplexers we can feed.

Destination Enabled: Destination Enabled/Disable

Destination Type: It defines the type of protocol used to transfer the encoded stream from the encoder to the multiplexer, you can choose between Tcp, Edi Tcp standard EDI protocol on Tcp, Edi Udp protocol standard EDI on Udp, the last one is not recommended if the data stream go through public networks (internet).

Destination IP Address: Multiplexer IP Address.

Destination Port: Multiplexer Port

Mux Label: In this field you can enter the name of the multiplexer that we are going to feed, the label has no effect on the configuration.

EDI TS Enabled: Enables the sending of the time stamp in the EDI blocks.

EDI TS Delay: Shift value inserted in EDI blocks, this produces a similar delay in inserting the content into the multiplexer stream.

UTC Offset mode: Allows you to choose how to manage the UTCO field present in the timestamp, in TAI Download mode the multiplexer will download the table containing the bulletin where the change of the leap second is announced as well as the current value, in manual mode it will be possible to insert in the next field UTC Offset the value of the seconds.

UTC Offset: is the value of the UTCO inserted in manual mode in the timestamp currently the value is equal to 5 seconds or Leap seconds 37 - TAI GPS offset 32.

For more information on the Timestamp, please refer to ETSI TS 102 693 V1.1.2

https://www.etsi.org/deliver/etsi_ts/102600_102699/102693/01.01.02_60/ts_102693v010102p.pdf

2.4.2 Pad configuration

Button Configuration PAD

PAD configuration for Encoder 1

PAD Enabled *
Yes ▼

Source Username: source1

User Password *
●
This password will be used for FTP and Windows Share

Transmit Timeout
30 ▼
Transmit slideshow and DLS data every seconds (from 20 to 60)

PAD Bandwidth Percent
10 ▼
PAD transmission bandwidth load (percent between 10 and 30)

Disable Metadata Extraction *
Yes ▼

Annotate images with metadata *
No ▼

XML Parser Enabled *
Yes ▼

Clicking the PAD key will open the "PAD configuration" window of the channel, here we can choose if we want to enable the Program Associated Data using the PAD Enabled drop-down menu, the User name is presented in the line below which will be source1 or source2 depending on the encoding process where we are, below it will be possible to set a Password for it; the credentials that will allow access to the folder containing the text file and the images will therefore be source1 or source2 with the relative password set, access to these resources is possible via ftp protocol on standard port 21.

Once logged in we will find ourselves in a folder containing a file named dl.txt and a pictures folder. The text file is read and transmitted by the encoder as DL dynamic label or if suitably formatted as DL+, the images inserted in the folder pictures will be transmitted as a Slideshow, one or more files are accepted in the typical formats: jpg, png, bmp, the files will be reduced to the 320x240 pixel format typical of slideshows, the size will be reduced up to a value that does not exceed 13KB.

If the pictures folder contains more than one image, these will be transmitted cyclically.

To make the interfacing of the encoder with the various playout easier, the RD Link software was developed, this is able to automatically manage the acquisition of the author, title of the song and of a possible cover and so it's able to create an artwork containing title, author, cover and station logo, for the configuration of RD Link, refer to the appropriate manual.

Transmit timeout: is the time between a transmission and the next of the Slideshow contained in the pictures folder, the minimum value is 20 seconds the maximum 120 seconds.

PAD Bandwidth Percent: is the percentage of band that will be subtracted the audio during the

transmission of the PAD (program associated data), the minimum value is 5% the maximum 30%

Disable metadata extraction: if you choose No it allows the extraction of the metadata of the streaming which will then be transmitted in the Dynamic Labels, if you choose Yes the extraction of the metadata is disabled, using ftp or samba sharing it will always be possible to write the data to be transmitted in the text file in the DLS.

Annotate images with metadata: allows you to superimpose the data of the DL and the current date and time on the transmitted Slideshows using two banners placed on the upper and lower part of the image.

XML Parser enabled: Enables the XML parser capable of acquiring the data appropriately tagged from a dl.xml file formatted according to the ETSI TS 102 980 standard and stored in the same folder where the dl.txt text file is present. Once the dl.xml file has been decoded, the parser will write the result in the dl.txt file which will then be read and transmitted in the appropriate data PAD tags. The dl.xml file is reread every 3 seconds, if the file contains more than 4 tags these are sent in blocks of maximum 4 every 4 seconds.

The encoder manages the sending of text and images according to this method: the text is sent every 2 seconds, the image is updated cyclically in intervals equal to the transmit timeout value, if the text or image change the encoder sends it immediately without waiting for the timeout to speed up updating the slide with the cover on the air, in this condition, if the transmission of a previous slide is in progress, this is interrupted to pass immediately to the more recent one.

2.5 DSP

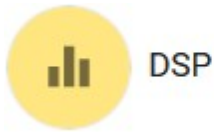

By clicking on the audio processor configuration icon the corresponding configuration menu will open.

The audio processor consists of a two-band AGC, one dedicated to frequencies below 200Hz, the other for the remaining audio components, a 6-band limiter, a clipper with distortion cancellation. At the end of the audio process there is Loudness limiter according to the ITU1770 standard, recommended for digital transmissions, this allows to harmonize the audio level perceived, by the user, making the channels of the multiplexer uniform listening



If there are two encoding processes in the encoder and therefore two audio processors, by clicking ENCODER1 or ENCODER2 at the top it is possible to switch from the setting parameters of the audio processor of the first encoder to that of the second and vice versa.

The top panel contains the audio processor operation indicators.

INPUT: Input Level

AGC: It displays the reduction level imposed by the two AGC, left band is the audio band from 0 to 200Hz, right band over the 200Hz

LIMITERS: 6 bands limiter values. Left bar is related to the lowest frequencies, right band the highest frequencies

ITU: Loudness limiter ITU1770 level.

OUTPUT: Process Output level.

In the menu on the top left it is possible to enable the encoder, activate or not the ITU limiter, load or save presets.

DSP Enabled: Audio Processor Enable/Disable

ITU Enabled: Enable Loudness Limiter ITU1770.

Preset on air: Shows the name of the preset on air.

Previous Preset: Shows the name of the previous preset if one parameter is changed.

Load preset: Allows you to load a previously stored preset or a factory preset.

Save preset: Allows you to save a preset.

Revert preset: Allows you to undo the changes made to an unsaved preset.

The configuration of a preset can be made by user changing the parameters in the menu: AGC, MULTIBAND, BASS EQUALIZER, ITU LIMITER.

AGC



This window contains the settings for the dual band automatic gain control (AGC) block, placed at the head of audio processing chain.

The automatic gain control performs a pre-levelling of the signal applied to the following compressors/limiters, keeping their working point almost constant.

Gate level: Gate level threshold. Below this level, the AGC and multiband limiter release is slowed down, range -50..0 dB..

Drive: indicates the AGC input driving level, thus determining the AGC maximum gain, range 0..20 dB..

Release: AGC release time setting (40% fastest, 200% slowest).

Band Link: set the maximum compression difference between the bass and middle/highs band.

Setting this value to zero, the bass compression level will be totally independent and this will cause also a mild auto-equalization.

Setting this value to 100%, it will force the bass compressor to have a gain never greater than the middle/highs band giving a sound very close to the original.

MULTIBAND



This window contains the parameters of the multiband limiter which elaborate the audio.

Drive: Multiband limiter drive level, increasing the drive the multiband increases its work, increasing the loudness, range 0..15 dB.

Band Threshold: All six-band limiters thresholds are adjustable in order to apply a dynamic equalization according to the user's taste. Lowering the limiting threshold of any band will result in attenuating the level of that band, while raising the threshold, will amplify its level, the range is -6..+3dB.

The six bands cutoff frequencies are :

B1: 100Hz and below

B2: 400Hz

B3: 800Hz

B4: 1600Hz

B5: 3200Hz

B6: 6400Hz and above

Brilliance: Set the amount of high frequency controlling the band 6, at 100% the amount of high frequency is the same, reducing this value till 0 the amount increases.

Release: Multiband limiter release time, (40..200) lower values reduce the release time increasing the loudness.

FinalClip Drive: Set the wideband final clipper driving level. Higher driving level corresponds to higher loudness, but will cause higher distortion, to reduce distortion we have introduced a particular new algorithm of distortion cancelling.

BASS EQUALIZER

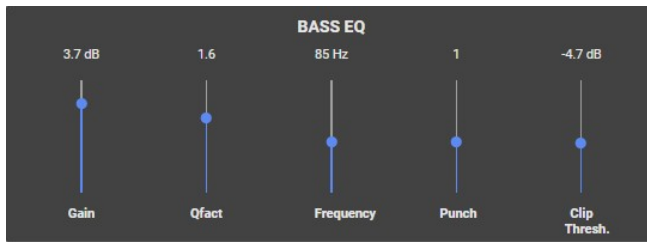

In this menu it is possible to process the low frequencies, highlighting particular frequencies and extending their duration over time.

Frequency: Parametric equalizer center frequency, this frequency can be attenuated or amplified, range 20..150 Hz.

Gain: Gain (boost) of parametric equalizer, range -6..+6 dB..

Qfact: Q-factor (bandwidth) of parametric equalizer.

Punch (0..2): Punch enhancer (0 off, 2 max). Give some nice "analog-style" bass enhancing.

Clip Thresh: Bass clipper threshold. Increasing the value the bass frequency will be controlled make by clipping, reducing the value the control will be made by compressor.

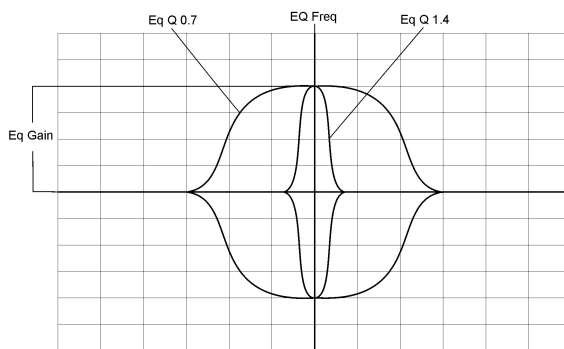

ITU LIMITER



In this menu it is possible to set the loudness limiter, this allows to harmonize the loudness of the various programs present in the multiplexer so as to have a passage from one content to another without significant volume jumps, normally we recommends a value between - 15 and -10 dB LKFS

The changes on the values will be applied automatically in a time less of one second, it's important remember if we are listening the on air signal that there is a latency of 2 seconds due to encoding, multiplexing and GPS synchronization, so when we change a parameter on audio processor the effect on audio will be heard after 3 seconds.

Once our preset has been created by clicking SAVE PRESET a window will appear where you can enter the name of our new preset, then clicking save will close the window and the preset will be saved.

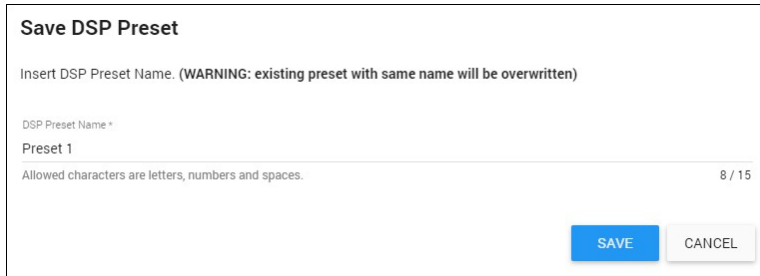

Save DSP Preset

Insert DSP Preset Name. (WARNING: existing preset with same name will be overwritten)

DSP Preset Name *

Preset 1

Allowed characters are letters, numbers and spaces. 8 / 15

SAVE CANCEL

If we want load a preset, is necessary click LOAD PRESET. a new window will open and here we can select the name of the preset.

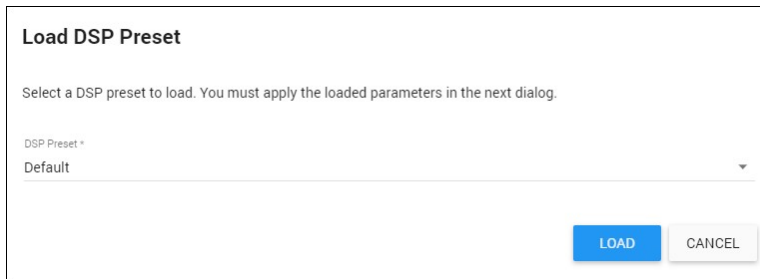

Load DSP Preset

Select a DSP preset to load. You must apply the loaded parameters in the next dialog.

DSP Preset *

Default

LOAD CANCEL

Selected the preset click LOAD and this window will close.

If is necessary delete a preset is possible to make it going in the [Maintenance Menu](#).



DELETE PRESETS
Delete unused DSP presets

DSP Preset *

Default

DELETE

Select the preset name to delete and click DELETE, the preset will be removed permanently.

2.6 Announcements



ANNOUNCEMENTS

In this menu is possible to configure the TA (traffic announcement), INFO (information transmission), ALARM (general alarm condition) and RT (Radio text) controls, these controls are sent via a communication protocol on port 80 of the multiplexer which will signal them to the receiver on Fig 0/18 and switch them using Fig 0/19.



Announcements for Encoder 1
Source Enabled



Announcements Source *
UECP (UDP)

UECP UDP Port *
5000

UDP port listening to UECP messages (from 1 to 65535)

UECP Site Address * **0** UECP Encoder Address * **0**

UECP Site Address to match (from 0 to 1023, 0 matches all) UECP Encoder Address to match (from 0 to 63, 0 matches all)

Use RT from UECP message *
No

Destination Enabled *	Dest. IP Address *	Dest. Port *	Channel *	API Key *
Yes	192.168.1.144 IP address 13 / 15	80 Port (from 1 to 65535)	0 Channel number (from 0 to 63)	12345 MUX API Key 5 / 16
No	0.0.0.0 IP address 7 / 15	80 Port (from 1 to 65535)	0 Channel number (from 0 to 63)	000000 MUX API Key 6 / 16
No	0.0.0.0 IP address 7 / 15	80 Port (from 1 to 65535)	0 Channel number (from 0 to 63)	000000 MUX API Key 6 / 16
No	0.0.0.0 IP address 7 / 15	80 Port (from 1 to 65535)	0 Channel number (from 0 to 63)	000000 MUX API Key 6 / 16
No	0.0.0.0 IP address 7 / 15	80 Port (from 1 to 65535)	0 Channel number (from 0 to 63)	000000 MUX API Key 6 / 16

In the Announcements page is possible set the parameters for the TA and RT over UECP or GPIO Port. INFO and ALARM are always present on connector GPIO.

Announcements Source: Source for the TA and RT activation. Source can be Serial, UDP, Parallel or mixed.

UECP UDP Port: UDP port if UECP over UDP is selected.

Baud Rate/Parity: Baud Rate and Parity Bit (8 data bit fixed) for UECP over RS232.

UECP Site Address/UECP Encoder Address: Address for UECP Protocol.

Use RT from UECP Message: Enable radio text reception from UECP.

At the end of the configuration parameters, we find 5 editable fields that show address and ports of the 5 different multiplexers we can feed.

Destination Enabled: Enable the transmission of the data to the MUX

Destination IP Address: MUX IP Address

Destination Port: MUX Port

Channel: Mux Channel

API Key: Key for enabling data channel between MUX and ENC.

2.7 Networking



NETWORKING

This menu allows you to modify the data of the network interface using the following parameters:

NETWORK CONFIGURATION

IPv4 Network parameters - eth0

IP Address *	Netmask *
192.168.0.10	255.255.255.0
Insert a valid IP address	Insert the network mask
Gateway IP Address	
192.168.0.254	
Insert the gateway IP address	

DNS CONFIGURATION

Name Servers Configuration

Primary DNS IP address *	
8.8.8.8	
Insert a valid IP address	
Secondary DNS IP address	
8.8.4.4	
Insert a valid IP address	

NTP CONFIGURATION

Network Time Configuration

NTP Default Servers *	
Yes	
NTP Server #1 *	NTP Server #2
0.pool.ntp.org	1.pool.ntp.org
Insert a valid IP address or domain name	Insert a valid IP address or domain name
NTP Server #3	NTP Server #4
2.pool.ntp.org	3.pool.ntp.org
Insert a valid IP address or domain name	Insert a valid IP address or domain name

NTP STATUS

Network Time Peers Status

remote	refid	st	t	when	poll	reach	delay	offset	jitter
*nettuno.ntp.irh	193.204.114.232	2	u	602	1024	377	12.245	0.261	1.674
-ns1.phuture.sk	10.0.0.1	3	u	527	1024	377	40.400	-4.028	4.207
+ntp.backplanedn	152.2.133.55	2	u	792	1024	353	131.645	1.722	5.060
+84.2.46.19	10.20.75.140	2	u	331	1024	377	34.666	0.207	0.442

NETWORK CONFIGURATION

IP Address eth0: IP address

Netmask eth0: Netmask

Gateway eth0: Gateway

DNS CONFIGURATION

Primary DNS IP Address: Primary DNS.

Secondary DNS IP Address: Secondary DNS.

NTP CONFIGURATION

This menu offer you the possibility to specify the addresses of the NTP servers necessary to the Encoder to synchronize the time and the clock, changing the NTP Default Servers from Yes to No you can specify up to four addresses, if you leave the choice in Yes the system search automatically the 4 NTP servers.

In the **NTP STATUS** menu is shown the actual status of the NTP servers contacted, the asterisk character " * " present before the name of the server denotes the server currently in use, it's important to verify, particularly the first time you start the Encoder, the presence of the servers in this page and the presence of the asterisk before one of these.

If in this page the server will not be showed after 5 minutes from Encoder startup, is necessary verify the network configuration and in particular the access to internet to the port 123 in Udp protocol.

2.8 Alarms



ALARMS

In this menu it is possible to set the parameters necessary for sending alarm emails and the restart times of the encoders in case of block.

ALARMS CONFIGURATION

Common parameters

Enable Alarms via Email *	No	Restart Interval *	1
		Restarts service after n minutes (from 0 to 1000, 0 is never)	
Encoder Description *	DAB Encoder	SMTP Server *	
Encoder description shown on alarm Emails	11 / 128		0 / 256
SMTP Port *	25	SMTP Authentication *	No
SMTP Server TCP port (from 1 to 65535)			
SMTP Username		SMTP Password	
Username for SMTP authentication	0 / 128	Password for SMTP authentication	0 / 128
SMTP requires SSL *	No	Sender Email Address *	debenc@localhost
		SMTP sender Email Address	16 / 256

TEST SMTP SERVER

Recipient #0

Email destination address

Destination Email Address *	destination@domain.it
Destination Email Address	21 / 256

+

In the case of blocking an encoder or missing the source, an alarm mail is sent to the enabled recipients; at the time of restoration, a second email is sent confirming the correct functioning of the encoder.

An alarm email is also sent if the fan stops or the temperature exceeds 65 degrees Celsius.

Enable Alarms via Email: Enable the email

Restart interval: indicates after how many minutes the supervision system restarts the encoder that has gone in block, if the value 0 is set, the supervision system will not restart any encoders blocked, it's important put a value => 1.

Every process of streaming encoding can be interrupted due to errors in the data flow coming from the internet, to avoid this we always recommend to feed the encoders with dedicated and stable streaming, in any case the supervision of the single process operates a maximum of 20 consecutive restarts before leaving the encoder in permanent lock state, once finished in this state will be the control system configurable in this session to restart the process again and to communicate via email the problem encountered.

If an encoding process has analog or digital input as its audio source and the audio level falls below the -70dB threshold for a time greater than 30 seconds, the supervision system will stop and restart the encoder. the operation will be repeated 5 times and will be signalled by the yellow LED on the front of the encoder relating to the process in alarm, when the fifth attempt to restart the encoder fails, the control system will wait for the "restart interval" time and will proceed with subsequent restart, as well as notify the event by mail, snmp and log.

Encoder description: is the name of the dab encoder that will be shown in the email

SMTP Server

SMTP Port

SMTP Authentication

SMTP Username

SMTP Password

SMTP requires SSL

Sender Email Address: is the address used for send email

TEST SMTP SERVER: by pressing this key it is possible to send a test mail to all the configured addresses so as to be able to verify correct operation.



pressing red button with + is possible add new receivers

Destination Email Address: allows you to specify the email address to send alarm messages to.

2.9 Snmp



SNMP

In this menu is possible to set the snmp (simple network management protocol), this is the most diffused remote control system for professional equipment.

SNMP CONFIGURATION
Common parameters

Enable SNMP agent *
No

SNMP Community *
public

SNMP agent port *
161

SNMP Community 6 / 32

SNMP agent UDP port (from 1 to 65535)

SEND SNMP TEST TRAP

TRAP destination #0
SNMP TRAP destination

Enable TRAP destination *
Yes

Host *
destination@domain.it

Community *
public

Destination Host 21 / 256

Community 6 / 256

Enable SNMP agent: enable or disable the access to the data of encoder by the snmp, the data request must be made by the external server.

SNMP Community: is the string that define the user name need by the control server to access to the encoder.

SNMP Port: is the port to access to the data by snmp, the default port is 161.

If you want to send the data by snmp to a server in case of alarms, you need to configure one or more trap. To enable a trap is necessary click the '+' button on the right down part of the window, each time you click, you can add a new trap.

Enable TRAP destination: enable or disable the trap destination with the host address specified after.

Host: is the address of the server which will receive the trap alarms generated by the encoder.

Community: is a sort of user name with which the encoder announce itself before sending data of a trap.



By repeatedly clicking the + key it will be possible to specify multiple trap recipients.

Send Snmp Test Trap: By clicking this button you can send a test snmp trap to all specified addresses.

Traps are sent in the following cases:

- if one of the processes stops and is restarted (this occurs after a prolonged audio loss)
- the fan rotation speed value goes to 0.
- the CPU temperature value exceeds 65 degrees centigrade.

2.10 Maintenance



MAINTENANCE

The following functions are available in the maintenance menu:

Time zone: Choose Time Zone

TIMEZONE
Set Encoder Timezone

Timezone *
Europe/Rome

SET

Encoder Firmware: allows you to update the system firmware, clicking browse opens a window where you can search for the file containing the new firmware, once selected must be clicked update and waiting for the system to restart.

ENCODER FIRMWARE
Encoder Firmware Upgrade

Select file BROWSE UPGRADE

License Upgrade: allows you to upgrade the license, enabling maximum 2 channels and the dsp audio processor.

LICENSE UPGRADE
Encoder License File Upgrade

Select file BROWSE UPGRADE

Encoder configuration: allows you to save the configuration of the mux in a file by clicking the Backup button and to load a configuration file using the Restore button; in the case of saving and restoring the parameters, everything except the network configuration addresses will be saved.

ENCODER CONFIGURATION
Backup and restore encoder config

Select file BROWSE RESTORE BACKUP

Reboot: allows you to restart the machine.

REBOOT ENCODER
 Reboot the system

Admin password: allows you to change the system administrator password.

ADMIN PASSWORD
 Change the password for the user 'admin'

Admin password * Repeat password *

Insert password

Delete Presets: allows you to delete the presets old digital audio processor.

DELETE PRESETS
 Delete unused DSP presets

DSP Preset *

License: contains information related to the product license, **Customer name** name to which the license is issued, **Machine Type** the product type, **Max Internal Encoders** the maximum number of encoders enabled, **Max Fraunhofer Encoders** the maximum number of encoders that could use the Fraunhofer high quality codec, **DSP enabled** activation of the audio processor.

LICENSE
 License Information

Customer Name:	ENCprova
Machine Type:	encoder
Max Internal Encoders:	2
Max Fraunhofer Encoders:	2
DSP Enabled:	true

Version: is the build release actually present in the encoder and the date of creation.

VERSION
 Build Number and Date

IDEnc build ebefc17 Fri, 20 Nov 2020

2.11 System



SYSTEM

The system menu shows the most important parameters of the encoder relating to the hardware platform and to the encoding processes.

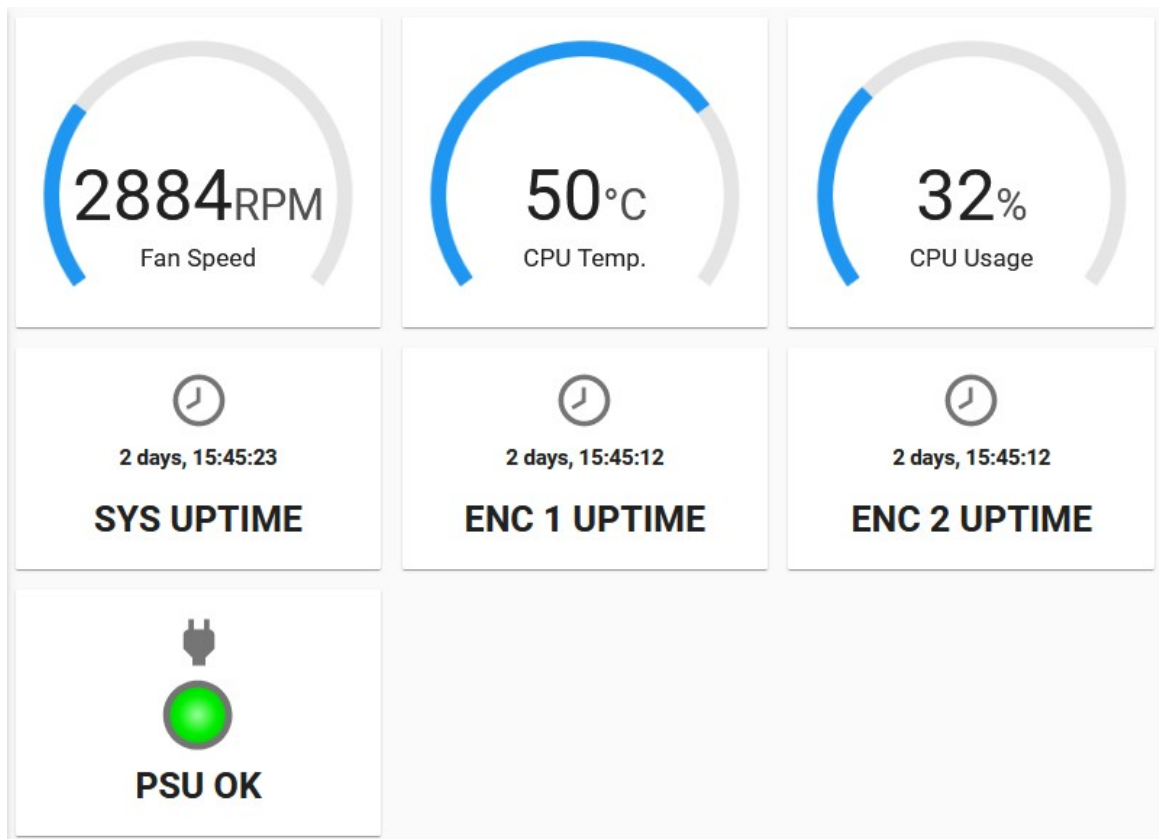

Fan Speed: the value indicates the rotation speed of the fan located on the right side of the encoder, the fan speed is controlled by the motherboard and if the CPU temperature exceeds 55 degrees the speed is increased until the temperature decreases.

CPU Temp: CPU temperature, when the value of 65 degrees is exceeded, an alarm is generated and send by snmp trap and by email, the alarm is also logged.

CPU Usage: CPU load expressed as a percentage.

Sys Uptime: indication of the time elapsed from the encoder start

Enc1 Uptime: indication of the time elapsed from the first encoding process start.

Enc2 Uptime: indication of the time elapsed from the second encoding process start.

PSU: status of the power supplies, the indication is green and shows PSU OK when both power supplies are working properly, in case of failure of one the indication turns red and PSU FAULT is reported, the alarm generates a trap snmp , sending an email and is logged.

2.12 Log



This page shows the list of alarms occurred during operation.

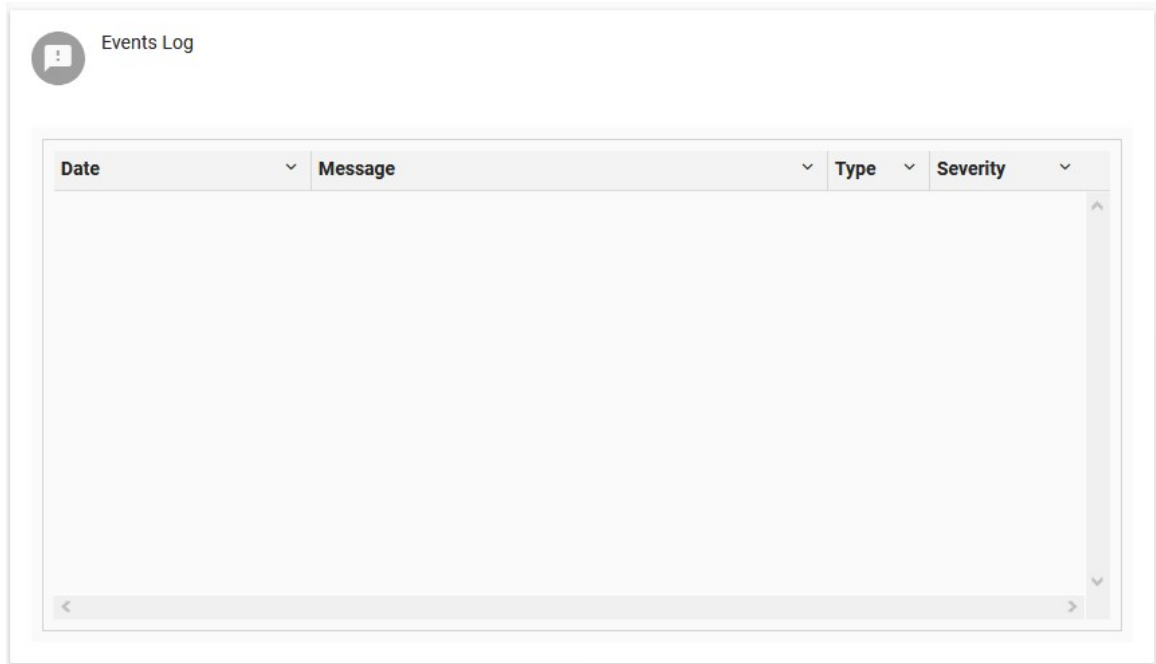

If the encoder is switched off or restarted the log list will be deleted.

Each row will contain the time in which the alarm originated or was resolved, the message specifying the reason, the type: alarm related to the malfunction of a hardware component (fan or power supply), or system if related to the software and finally the importance: warning, alarm or OK if resolved.

Section

Recovery

3

3 Recovery

The recovery function is a system user interface reachable through the use of a monitor and a keyboard connected to the rear connectors, USB/PS2 for the keyboard and VGA / HDMI for the monitor.

If the administrator password is lost or if the IP address of the ethernet interface is forgotten, it is possible to access the system parameters via this menu and then proceed to reset the password.



3.1 Menu and factory reset

At the pin request enter the default value 1234 and press enter, then a window will be presented with the following options available, to choose one, simply select it with the arrows and then press enter:

Platform information: provides the data of the system license.

Services status: shows the status of the services that are running, that is, the enabled encoders.

Networking setup: allows you to change the IP addresses of the two ethernet interfaces and the DNS, it is recommended not to put addresses of similar class in the two ethernet interfaces and never to configure a gateway in the eth1 interface.

Issues escalation setup: allows you to set the parameters for sending an alarm mail

Admin password set: allows you to change the administrator password.

Change PIN: allows you to change the PIN code to access the recovery interface (in case of loss of this code it will no longer be possible to access the recovery interface).

Factory reset: reset the system to the default parameters.

