

DMPX Digital stereo coder

User's manual



Author	A.Tomassini
Version	3.2.4 - 05/11/2025
Copyright	© 2025 ITEL Elettronica e Telecomunicazioni Snc

Table of contents

Section 1 Description	5
1 List of changes	5
2 Warnings	5
3 Front panel	6
4 Rear panel	6
5 Editing and navigation	7
Section 2 Front panel display	10
1 RDS Coder	10
RDS level and flags	10
PI, PTY and AudioMuteRDS	11
PS and Radiotext monitor	11
PS Editor	11
RT Editor	12
AF list Editor	12
2 Audio input setup	13
Audio levels monitor and input level setting	13
Audio source setup	13
Audio fallback setup (audio backup)	14
3 Audio output setup	15
Audio output regulation	15
4 MPX output setup	15
MPX modulation and pilot subcarrier setup	15
Output level setup	16
Preemphasis Limiter and Clipper	17
5 System setup	17
Display, Source Dependent Presets, Device ID	17
GPI and MPX changeover option (Split)	17
PassCode Setup	19
Ethernet setup	19
System info	20
Options	20
Login window	20
Section 3 Programmimg software	24
1 Main window	24
2 Audio/System	25
Audio input-output	25
System setup	26
3 Loading and saving system	27
4 RDS	28
RDS Flags window	28

PS window	30
Radiotext window	31
AF Lists window	32
Editing	33
A Method	34
B Method	34
Loading and saving RDS coder configuration	36
5 Passcode setup	37
Section 4 RD Link	39
1 Radiotext Plus	39
2 Monitor	41
3 Configuration	43
Setup	43
Program ID.....	43
Radiotext Plus and dynamic PSN.....	43
TA - Clock time.....	44
Communication interface and additional settings	45
Raw Text Importer	46
Word filter	47
4 Scheduler	48
Section 5 Streaming audio module	53
1 Quick setup	53
2 Audio decoder	53
Status	57
Streaming settings	58
Network settings	59
System settings	61
Alarm settings	62
Active alarms	62
Alarm logs	63
SNMP settings	63
Split control	64
FW upgrade	65

Section

Description

1

1 Description

This device is a fully digital stereo encoder with preemphasis limiter and optional RDS encoder.

1.1 List of changes

1.1.0	17/06/2014	first release
2.0.0	23/09/2014	updated to new firmware 2.0 features
2.0.1	20/11/2014	updated to new firmware 2.1 features
3.0.0	10/03/2015	updated to new firmware 3.0 features
3.1.0	18/12/2015	MPX coder version only features added
3.1.0	25/01/2016	updated to new firmware 3.1 features
3.2.0	14/09/2016	updated to new firmware 3.2 features
3.2.1	30/10/2017	updated to new firmware 3.2.1 features
3.2.2	12/01/2023	updated to new firmware 3.2.2 features

1.2 Warnings



Before attempting any operation, please follow the safety instructions contained in the following paragraph.

The producer declines any liability for damage to people or things due to non-compliance, even if partial, of the following indications

- Ensure that the supply voltage corresponds to what is indicated on the apparatus.
- Ensure that the electrical system is equipped with a ground connection.
- Use only power sockets and cables with ground connection
- Disconnect power before attempting any operation inside the device.
- The power cutting device is the power cord, so this should be easily accessible and the socket must be positioned close to the apparatus.
- Any operation involving the access to internal parts must be performed only by trained service personnel.

1.3 Front panel



Front panel indicators and rotary knob

- RDS: RDS is active, if the led blinking the "AudioMuteRDS" function is active, see paragraph PI PTY
- CLIP: The analog input level is too high.
- DIG IN: AES/EBU digital input is selected as audio source
- NET: Network audio is selected as audio source(option).

Menus navigation and parameter editing is done through the rotary knob.

1.4 Rear panel

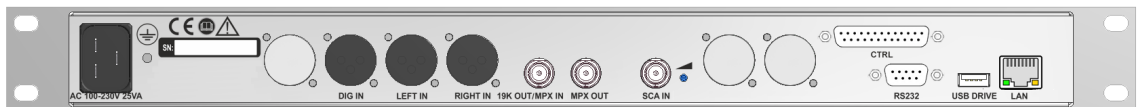

Connectors on rear panel

- DIG OUT (XLR M) AES/EBU output (option)
- DIG IN (XLR F) AES/EBU input
- LEFT IN (XLR F) Left analog input
- RIGHT IN (XLR F) Right analog input
- 19K OUT/MPX IN (BNC F) 19KHz output for external RDS encoder synchronization. (1Vpp trapezoidal wave) or MPX input for audio changeover (option)
- MPX OUT (BNC F) Composite MPX output (+6/-6dBm)
- SCA IN (BNC F) External SCA / RDS input (will be mixed to MPX output with a gain of -20dB)
- LEFT OUT (XLR M) Left channel analog output (option)
- RIGHT OUT (XLR M) Right channel analog output (option)
- RS232 (DSUB 9F) RS232 connector
- USB DRIVE (USB-A) USB connector for fallback audio on external drive (available on Ip Audio Stream option)
- LAN (RJ45) LAN connector for remote control or streaming audio module

1.5 Editing and navigation

Menu navigation and parameters editing is done by the front panel knob.

On the main menu which appears after firmware boot, is possible to select the submenu for the various settings.

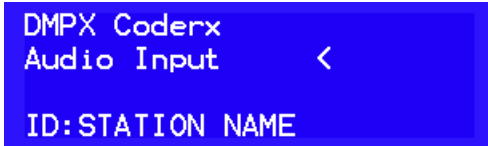

Pressing the knob, will enter the selected submenu.



Once entered in the desired sub-menu, if there are adjustable parameters, you can proceed to editing

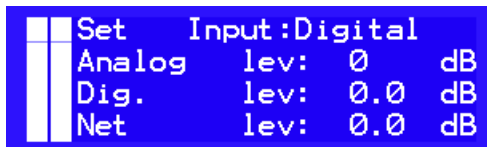

Pressing the knob, an asterisk "*" will appear next to the first editable element. This will not happen if, on the current window, there are no editable parameters.

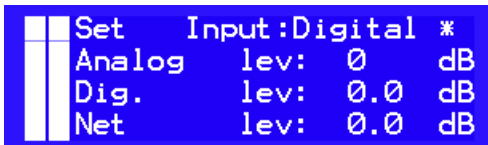

Turn the knob to position the "*" cursor on the other editable elements of the current window.

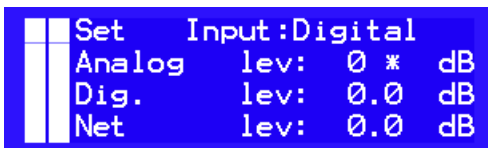

If you want now to change the analog input sensitivity, press the knob again. A "<" symbol will appear next to the parameter to indicate that this is being edited.

```

Set      Input:Digital
Analog   lev:  0 < dB
Dig.     lev:  0.0 dB
Net      lev:  0.0 dB

```

Turning the knob, you now will modify the selected parameter's value.

```

Set      Input:Digital
Analog   lev: -6 < dB
Dig.     lev:  0.0 dB
Net      lev:  0.0 dB

```

Once set the desired value, press the knob again. The cursor will switch to "*" again, indicating that items navigation mode is now active and other items can be selected and edited as described before.

```

Set      Input:Digital
Analog   lev: -6 * dB
Dig.     lev:  0.0 dB
Net      lev:  0.0 dB

```

If editing is however terminated, press the knob again and the "*" cursor will disappear and you can rotate the knob to navigate to other windows.

```

Set      Input:Digital
Analog   lev: -6  dB
Dig.     lev:  0.0 dB
Net      lev:  0.0 dB

```

Inside any submenu, pressing the knob for more than 3 seconds, will cause a jump to the main menu.

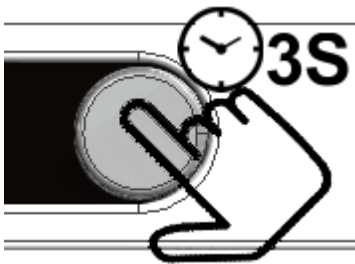

```

DMPX Coderx
Audio Input  <
ID:STATION NAME

```

Section

Front panel display

2

2 Front panel display

Following are listed all menus and functionalities available on the current firmware release.

2.1 RDS Coder

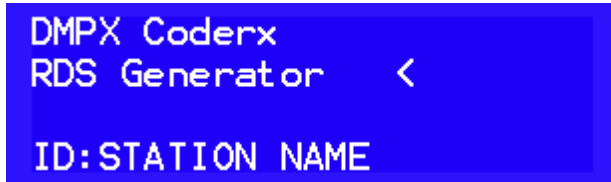

Into this section are comprised all functions and menus related to the optional RDS encoder.

2.1.1 RDS level and flags



RDS(ON/OFF): sets the coder on and off.

LEV: RDS subcarrier level

Edit DS: DATA SET selection for setting parameter ^[1]

Active DS: on air DATA SET selection ^[2]

TP (ON/OFF): sets the TP flag status

TA (ON/OFF): sets the TA flag status

RT (ON/OFF): radiotext enable

MS (MUS/SPC): sets the MUSIC/SPEECH flag status

COMPR (ON/OFF): sets "COMPRESSED" flag status

ARTIFICIAL HEAD (ON/OFF): sets "ARTIFICIAL HEAD" flag status

The "mono/stereo" flag is switched automatically, depending on the [MPX modulation](#) type selected.

^[1]In the "Multizone" version there are two sets of RDS configurations: DATA SET0 and DATA SET1 (DS0 and DS1). The data sets can be recalled via command on the communication protocol or via the RD-Link program. The data set change via RD-Link occurs when it receives the SPLIT ON / SPLIT OFF command in the "CommandText" tag of the .xml file (currently only available in some automation systems); upon receiving the command, the device WILL REVERSE the dataset on air (if DS0 is active it will broadcast DS1 and vice versa).

By selecting the DATA SET to edit with "Edit DS: " you can insert all the data in the subsequent menus; if the "Edit DS:" item is set to 0 all the data in the menus (flags, PSN, RT, AF list) concern the set 0, if "Edit DS:1" the data refers to set 1.

^[2]Active DS sets and/or displays the data set currently on air.

2.1.2 PI, PTY and AudioMuteRDS

```

PI: 5330
PTY: 09 Varied
AudioMuteRDS: 0N
SAVE

```

PI: PI code setting

PTY: Program Type, settings

AudioMuteRDS: when enabled, it turns off the RDS encoder when audio input is muted. This to prevent receivers to tune on a muted frequency when the same area is already covered by other repeaters. The mute timeout, AlmTime, can be set into the Fallback page. When the RDS encoder is switched off because of audio mute, the front panel RDS green led will be blinking.

Changes will take effect once saved.

2.1.3 PS and Radiotext monitor

```

PS MON   I MY RADIO I
RT MON My Radio My best
radio in town

```

PS MON: Program Station Name actually on air.

RT MON: Radiotext actually on air.

If the Radiotext Plus is active for the currently aired Radiotext string, a "+" symbol will be appended to the "RT" label.

Radiotext Plus, Dynamic PSN and CT (clock time) functions are available using the supplied software RD-Link

2.1.4 PS Editor

```

PS      1  :MY RADIO
Dur(secs): 2 SAVE DEL

```

In this window you can enter and edit PS strings that will be displayed by the receiver, each of which can be up to 8 characters long.

PS 1..24: selection of the item to edit.

Dur (secs): display time, in seconds, of the currently selected string . A duration of zero, will disable the display of the string.

SAVE: Save the modified item

DEL: delete the selected item

User must save changes before selecting a new string or before exiting the window, otherwise they will be lost

2.1.5 RT Editor

```
RT 2<:My Radio My best
radio in town
Dur(mins): 1 SAVE DEL
```

In this window you can enter and edit RT strings that will be displayed by the receiver, each of which can be up to 8 characters long.

RT 1..24: selection of the item to edit.

Dur (mins): display time, in minutes, of the currently selected string . A duration of zero, will disable the display of the string.

SAVE: Save the modified item

DEL: delete the selected item

User must save changes before selecting a new string or before exiting the window, otherwise they will be lost

2.1.6 AF list Editor

```
AfList: 1 Freqs:14
Freq #: 1 101.0
Freq INSERT DELETE
List SAVE CLEAR
```

Alternative frequencies editing window .It is possible to insert up to 25 frequencies on the first list for the method "A", or 24 lists for method "B". For more details on the differences between the A and B modes, please refer to the [AF List window](#) of programming software.

AfList 1 ... 24: selection of the AF list to be edited.

Freqs: indication of the number of frequencies into the selected list.

Freq #: selection of the frequency number in the list, from 1 to 25, to be edited.

Freq INSERT: Insert a new frequency in the "Freq #" position. The other frequencies in the list will be shifted accordingly.

Freq DELETE: the current frequency will be deleted.

List SAVE: saves the changes

List CLEAR: deletes all frequencies in the current list

Notes:

The list, once modified, will be used only after it has been saved using the SAVE button. Selecting a different list (AfList) or exiting the editing window before saving the list, will result in losing all changes.

Any empty frequencies (--.) eventually contained into the list, will be deleted automatically upon saving.

2.2 Audio input setup

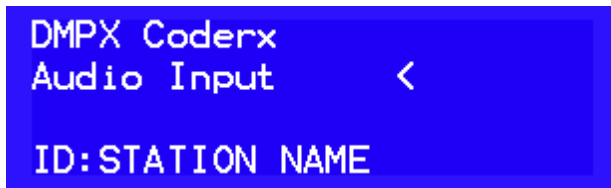

In this section are present all controls related to audio sources and [automatic audio fallback](#)

2.2.1 Audio levels monitor and input level setting



The bars are showing the input signal peak level: the input level must be adjusted to have the reading peaking around 0dB. The single bar below shows, with a long decay time constant, the instantaneous clipping level of the input signal. Short peaks up to +3dB are quite normal, especially when the input signal, despite it was already compressed - limited by a suitable FM broadcasting processor, is then transferred through MPEG compression.

It is possible to adjust the clipping threshold in the "[Preemphasis Limiter and Clipper](#)" menus.

The input level of the selected channel can be adjusted, but the channel will not be put on air. To change the on air input channel, the following window must be used.

2.2.2 Audio source setup

Audio input: Analog, analog input
Digital, AES/EBU input
NetAudio, streaming audio input.

Analog lev: audio input attenuator level. This adjustment sets the input level to the A / D converter. The nominal level is indicated in the bars:

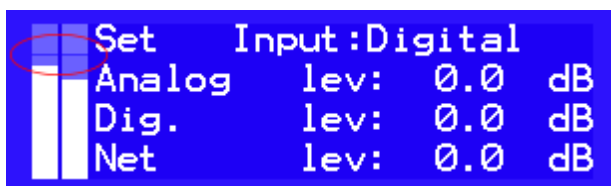

The initial adjustment of the input level should be made so that the maximum analog input level is equal to or only slightly above that limit.

In no case the front panel "CLIP" led should light.

Dig. lev: AES/EBU level adjustment

Net lev: streaming module level adjustment.

The adjustment of the individual channels is in 0.1dB steps.

2.2.3 Audio fallback setup (audio backup)

The processor can be set to automatically switch to an auxiliary input source if the main input audio level is below a minimum threshold.

```
Fallback:OFF OnAir:DIG
x I1:ANA AlmTime : 30
o I2:DIG BackTime:120
o I3:NET AlmThr: -60 dB
```

Fallback (ON/OFF): Enable / Disable automatic audio fallback on backup source.

OnAir: audio source actually on air

I1 - I2 - I3: Channel list. The channel are listed by order of priority, with maximum priority assigned to channel 1.

When an high priority channel will become unavailable, it will be replaced by a lower priority one until its recovery.

AlmTime: Alarm timeout

Back Time: Back timeout. It is the time for which the main audio source must be above the minimum threshold before it can be set back on air.

AlmThr: minimum audio level threshold

The main audio source is considered valid If the level of both channels L / R are above the alarm threshold. If a single channel is less than the alarm threshold for a period longer than the alarm timeout, the backup source will be put on air.

When the main audio source will recover, once elapsed the "Back Timeout", it will be put back on air.

Changes will be applied upon exiting the menu.

2.3 Audio output setup

```
DMPX Coderx
Audio Output  <
ID:STATION NAME
```

This section contains the settings relating to the DIG OUT - L R OUT audio outputs (only if the optional outputs are present).

2.3.1 Audio output regulation

```
ANA Out lev : 0.0 dBu
DIG Out lev : -6.0 dBFS
OUT deemph : 50uS
Out pos: Post clip&flt
```

ANA LR Out : audio output level on rear XLR Left-Right OUT connector.

DIG LR Out : output audio level on rear XLR DIG OUT connector

Out deemph: output audio deemphasis. This is related only to the audio output, not to MPX output.

Out pos: point of acquisition of the output signal, it can be selected form:

Post clip&flt: output signal is taken after clipper and lowpass filter.

Pre filter: output signal is taken prior the lowpass filter, but after the clipper.

Pre clipper: output signal is taken before the clipper.

2.4 MPX output setup

```
DMPX Coderx
MPX Output  <
ID:STATION NAME
```

2.4.1 MPX modulation and pilot subcarrier setup

```
Modulation : Stereo
Preemphasis : 50us
Pilot Level : 5.0    KHz
Pilot Phase : 0.00  Deg
```

Modulation (stereo, mono l+r, mono L, mono R):

Stereo: stereo modulation

Mono L+R: monoaural modulation from L+R channels sum.

Mono L, Mono R: monoaural modulation from a single channel.

Preemphasis: 50/75uS preemphasis, it should be set according to local FM broadcasting standards.

Pilot level: 19KHz pilot tone injection level.

Pilot Phase: pilot tone phase adjustment.

2.4.2 Output level setup

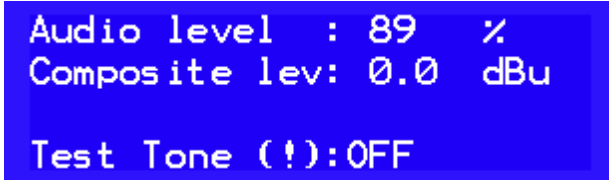

```
Audio level : 89 %
Composite lev: 0.0 dBu
Test Tone (!): OFF
```

Audio level: percentage of audio signal (L+R, L-R) into the composite MPX signal.

In case of monoaural broadcasting, without RDS and pilot subcarrier, this level can be left at 100%, and this will produce a deviation of 75KHz.

In all other cases it should be reduced according to the level of injection of the two subcarriers, otherwise overmodulation will occur.

For example, if a RDS subcarrier of 2KHz and a pilot tone of 6KHz are desired, the audio signal level can not be greater than

$$100 * (1 - ((\text{PilotCarrierDeviation} + \text{RDSCarrierDeviation}) / 75))$$

which, for the example described above, will correspond to:

$$100 * (1 - ((6 + 2) / 75)) = 89.3\%$$

Composite level: MPX output level.

Test tone (!): when activated, will put on air a 400Hz tone, having an amplitude equal to 100% modulation.

If RDS and pilot subcarriers were correctly set, the final modulation will not go above this limit.

2.4.3 Preemphasis Limiter and Clipper

```
Preemph Limiter: OFF
Output CLipLev : 0.1 dB
```

Preemph limiter: enables a preemphasis limiter to prevent sibilance splatter when the input material was not already processed through a processor expressly designed for FM broadcasting.
Clip level: adjustment of audio clipping threshold referred to 0dB.

2.5 System setup

```
DMPX Coderx
System      <
ID:STATION NAME
```

2.5.1 Display, Source Dependent Presets, Device ID

```
Contrast : 16
ID:STATION NAME
```

Contrast: display contrast adjustment.

ID: device identifier. It is a 16 characters long label which will be shown in the main menu screen, useful for identification when multiple devices are installed.

2.5.2 GPI and MPX changeover option (Split)

```
76543210
GPI status : 00000000
Split ctrl port:OFF
Invert split status:OFF
```

In this menu it is possible to remotely select the channel to be broadcast or manage an MPX advertising split in output (option). The election is possible via GPI, serial and Network card.

GPI status: status of the 8 available ports, from 7 to 0.

Split ctrl port: enable the function and select the communication mode.
OFF: disabled function.

GPI: active function on CTRL port.
 Serial: active function on RS-232 port.
 Network: active function on Ethernet port.

Invert split status: invert commutation MPX Input set on GPI mode
 OFF: without command it is set in [NETWORK] mode.
 ON: without command it is set in [SPLITTING] mode.

The split status is shown at the top of the display.
 In [SPLITTING] mode, in MPX output there is the processed signal coming from Analog or Digital Inputs or Net Ip stream (if present).
 In [NETWORK] mode, in MPX output, the signal applied to MPX IN is present.

Rear Connectro GPI (CTRL)

GPI port status:

- 0: Pin 6 - Set ANALOG Input
- 1: Pin 2 - Set DIGITAL Input
- 2: Pin 7 - Set NET/IP Input
- 3: Pin 3 - Set MPX Input (SPLIT)
- 4: Pin 8 - Not used
- 5: Pin 4 - Not used
- 6: Pin 9 - Not used
- 7: Pin 5 - Not used

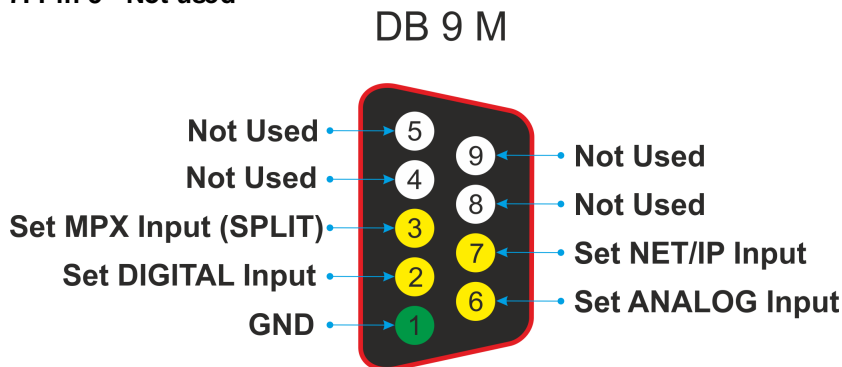

The inputs are activated by grounding the relative pin or by providing a voltage from 5 to 12VDC, in this case the jumpers placed on the board inside the device will have to be moved from the "CLOSE" to "VIN" position.

The selection of the channels through the GPI port takes place with exclusive priority on a single channel, if more inputs are activated at the same time the channel is restored before the selection, only the MPX channel has absolute priority and at each activation it does not take into account the status of the other 3 inputs by bringing the MPX IN signal to MPX OUT.

Example 1: the Analog channel is on the air, pin 2 is activated by broadcasting the Digital channel, at the same time pin 7 NET / IP is also activated, since the selection of two channels is not valid at the same time, the channel returns to air Analog.

Example 2: the Digital channel is on the air, pin 6 is activated by broadcasting the Analog channel, at the same time the MPX pin 3 is activated, the analog channel remains active but the MPX output is switched to MPX IN.

Network command by lan:

By selecting Network on "Split ctrl port" commands can be sent via LAN using the UDP protocol with standard ethernet card, the TCP protocol with IP Streaming option card.

```
[AB010103] select analog input
[AB010200] select digital input
[AB010301] select NET/IP input
[AB010406] / [AA010001] select MPX input
[AB010002] o [AA010100] return on main channel
```

The selection command must be repeated continuously otherwise the device re-enters the main channel.

2.5.3 PassCode Setup

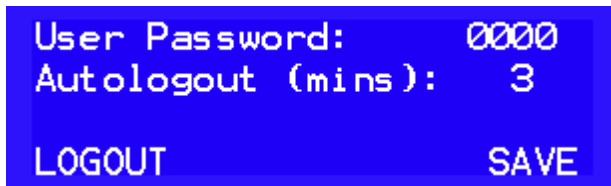

```
User Password: 0000
Autologout (mins): 3
LOGOUT SAVE
```

User Password: in this section the user can enter a numeric password that will be required for accessing the device. Setting "0000" (default value) will disable the password prompt.

Autologout (mins): Automatic lock timeout. If no action is done on the front panel knob within the specified time interval, the device will enter into lock state and the user will need to re-enter the password to log in again.

LOGOUT: immediate logout and lock.

SAVE: Saves any changes made to the numeric password or the duration of the automatic logout timing.

2.5.4 Ethernet setup

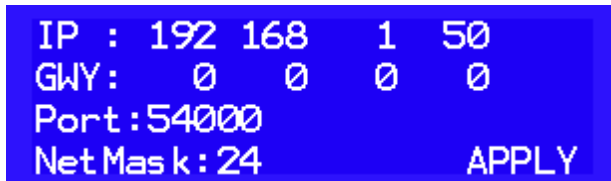

```
IP : 192 168 1 50
GWY: 0 0 0 0
Port: 54000
Net Mask: 24 APPLY
```

IP: current ip address

GWY: gateway address

Port: UDP port number

NetMask: netmask in CIDR notation.

APPLY: apply and save changes.

This page is visible only if the network module is installed.

2.5.5 System info

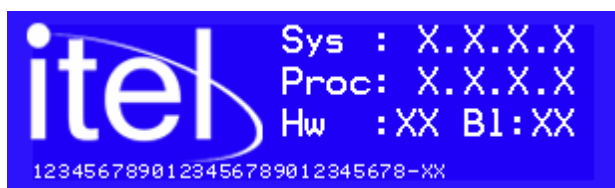

Sys: operating firmware release

Proc: audio processor and MPX coder firmware release

Hw: hardware release

BL: MCU bootloader release

SN: serial number

2.5.6 Options

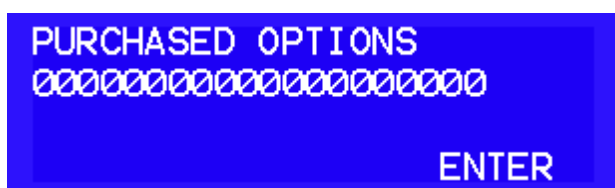

In this window the user must enter the code to enable the optional features.

Once entered the code for the desired option, go to the "ENTER" button and, when it will flash, push the front panel encoder.

The device will verify the code and, if found correct, will activate the requested option.

Example for RDS coder:



2.5.7 Login window

To protect the device from unauthorized operation, a security code can be enabled by accessing the System menu, [Set password](#).

When the device is turned on (or the auto logout time is elapsed), the login page will be shown where the pass code is to be entered.

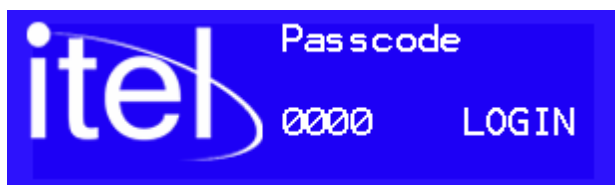

LOGIN: when the correct pass code is entered, will log in user.

Pass code lost or forgotten: after the 20th unsuccessful login attempt, an unlock code will be displayed. Call customer service and tell this code in order to get back your pass code.



Section

Programming software

3

3 Programming software

A PC based software Processor Programmer, compatible with 32 and 64 bits Windows Xp, Windows 7, Windows 8.X, Windows 10, is provided for processor remote control and setup.

Connection is done through:

- serial port 9600 baud 8N1
- ethernet port TCP-IP (if optional streaming module is installed)
- ethernet port UDP

3.1 Main window

In the main window the type of connection can be selected, via COM port or through Ethernet port using TCP-IP (needs streaming module) or UDP (needs ethernet module). Once the communication mode is set up and the processor connected, press "Connect". If communication is correct, the program will read all internal settings and device information.

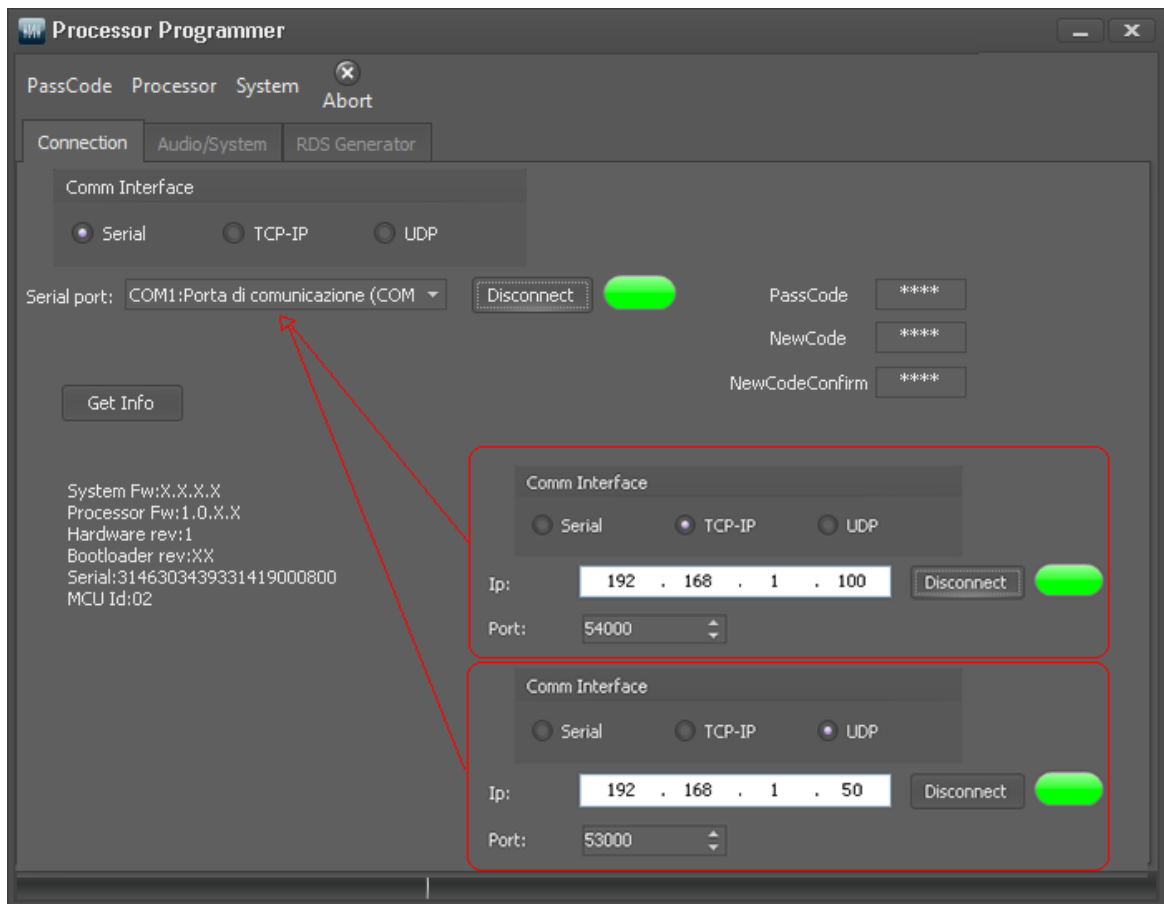

3.2 Audio/System

This section contains the audio process controls, setting of the audio input and output sources and system parameters.

3.2.1 Audio input-output

This page allows for selection of on air audio input, changing audio output parameters, setting up the audio fallback.

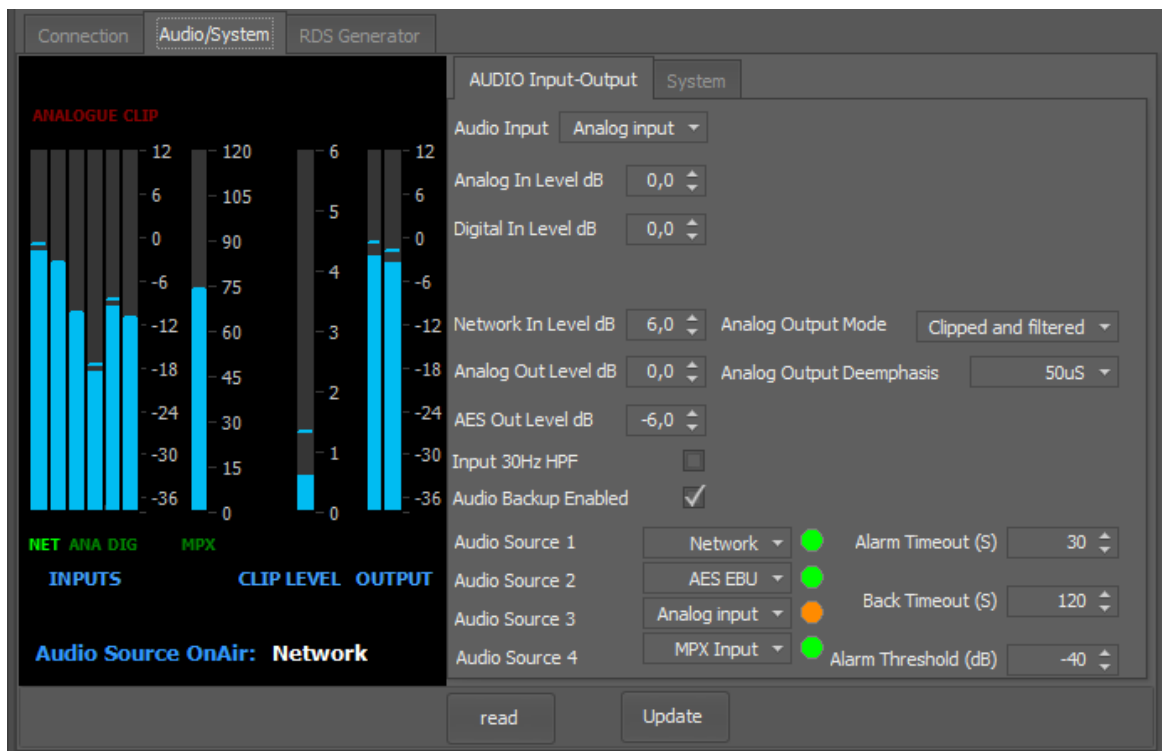

For a detailed description of the following parameters, please refer to [audio input setup](#), [audio output setup](#).

[Audio Input](#)

[Analog InputLevel](#)

[Digital InputLevel](#)

[Network InputLevel](#)

[Audio OutputLevel](#)

[Audio Backup Enabled](#)

Read: read parameters from the processor

Update: send changes to the processor

3.2.2 System setup

In this page it is possible to enable and adjust the optional RDS encoder carrier level, the pilot carrier, insert and adjust the network parameters.

The network parameters are related to the optional network module only. If the streaming module was installed, network configuration will be done through the web server of the module.

For a detailed description of the following parameters, please refer to [MPX output setup](#) and [System setup](#)

[RDS Enabled](#), [RDS level](#), [Pilot Level](#), [Pilot Phase](#), [Modulation](#), [Preemphasis](#), [MPX Output Level](#), [MPX Audio Level](#), [NET IP](#), [NET MASK](#), [NET GATEWAY](#), [NET PORT](#)

Read: read parameters from the processor

Update: send changes to the processor

3.3 Loading and saving system

The remote control software allows to load and save the system configuration through the "System" menu, and this includes all parameters listed under "System" and ["Audio Input-Output"](#) tabs.

Save System config to Disk

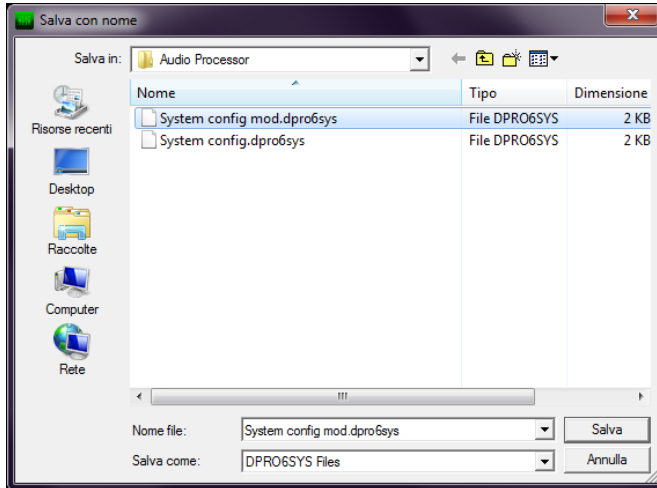
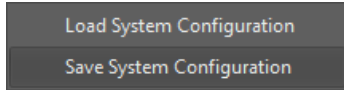

the system configuration will be saved to disk.

Load System config from Disk

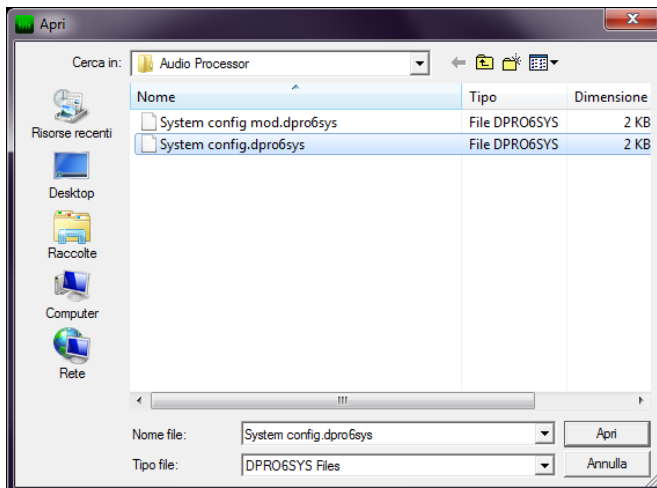
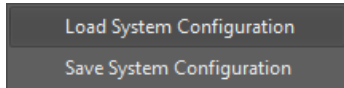

the system config preset loaded in.

3.4 RDS

RDS configuration pages will be visible only if the optional RDS coder was enabled.

3.4.1 RDS Flags window

This window contains the configuration parameters of the RDS encoder.

RDS ENABLED: enable RDS coder.

PTY: Program Type

Set the program type.

Many receivers are equipped to select the received stations based on the format preferred by the listener.

PI: Program Identification

Identification code of the station.

The code consists of 4 digits, the first digit indicates the country of origin, the second represents the area of coverage and the last two identify the station into its coverage area.

First digit, the country of origin of the program. You may write it directly into the "PI Code" editbox or select it using the "Country" dropdown list.

A list of some country codes is reported in appendix A.

For the second, according to the coverage area, choose one of the following codes:

0	local coverage, <i>the station is supposed to have one frequency only</i>
---	---

1	International coverage
2	National coverage
3	Supra-regional coverage
4..F	area codes for regional coverage stations

Note: the local coverage code "0" is intended for stations having one frequency only, so its use is intended just in this case. If the station has more than one frequency, a supra regional (3) or regional code (4 to F) must be used. Using the local coverage code (0), make many receivers to ignore the alternative frequencies tables.

The two last digits uniquely identify the station into its coverage area and shall be different amongst all other stations broadcasting over the same area.

Some examples:

5001: Italian radio station (5)	local coverage	(0),	program identifier code 01
5202: Italian radio station (5)	national coverage	(2),	program identifier code 02
54AF: Italian radio station (5)	regional coverage	(4),	program identifier code AF

TP: Traffic program

This flag indicates that your station, during normal programming, broadcasts traffic programs.

TA: Traffic Annonunce

Traffic Annonunce on air.

This flag should be set when traffic related news are being broadcasted.

For this reason, the TA flag can be switched by the external control port.

MUSIC: This flag indicates if the station main format is music or speech.

Some receivers use this information to apply a different tone equalization or volume according to whether music or speech is being broadcasted.

It is possible to switch this flag externally, using the external control port.

ARTIFICIAL HEAD: This flag indicates that the program was recorded using an artificial head.

This device is a dummy human head with two microphones inserted into the auditory canals, used during the recording process of the performance or live event, to accurately reproduce the original spatiality.

COMPRESSED: This flag indicates that the program was compressed.

ENABLE RADIOTEXT: Flag to enable radiotext group (2A) transmission.

If disabled, only OA groups will be trasmitted.

SWITCH OFF RDS on AUDIO MUTE: enabling RDS coding to be turned off in the absence of outgoing audio. This avoids the possibility of tuning into a mute frequency, the RDS off function is traced with the flashing of the green LED on the front of the device.

STATION ID: This 16-chars string can be assigned to the coder for its identification.

It could be its destination, the site to which the encoder is assigned, or the name of the radio which owns it.

It will not be shown anywhere else, neither transmitted into any RDS block; it is only a label to identify the processor.

3.4.2 PS window

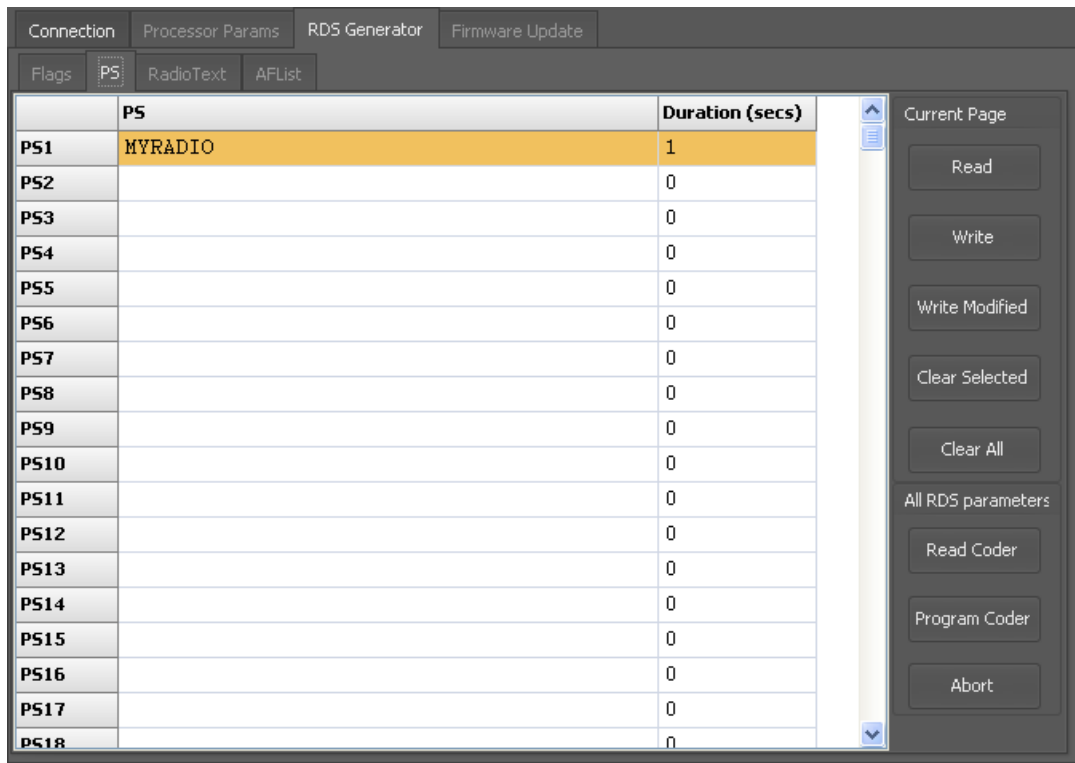

In this window, It is possible to enter the program station names, each of which can be up to 8 characters long.

For each string you can set the display duration time in seconds.

A duration time of 0, disables the corresponding string.

READ: read all PS strings from the encoder.

Warning: all strings on the grid will be overwritten.

WRITE:transfer all strings on grid to the coder.

Warning: the strings on the coder will be overwritten.

WRITE MODIFIED:transfer only modified entries

CLEAR ALL:clear all strings which are on the grid.

CLEAR SELECTED:clear all selected strings on the grid.

3.4.3 Radiotext window

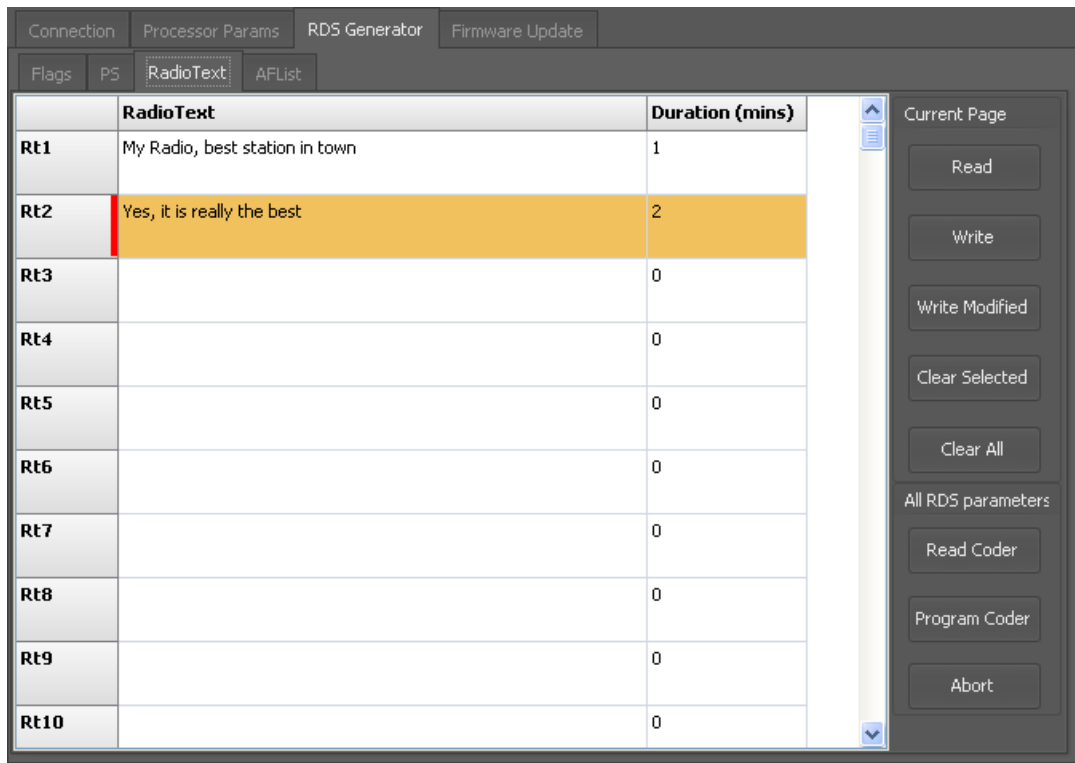

In this window, It is possible to enter the radiotext strings, each of which can be up to 64 characters long.

For each string you can set the display duration time in minutes.

A duration time of 0, disables the corresponding string.

READ: read all radiotext strings from the encoder.

Warning: all strings on the grid will be overwritten.

WRITE:transfer all strings on grid to the coder.

Warning: the strings on the coder will be overwritten.

WRITE MODIFIED:transfer only modified Radiotext entries

CLEAR ALL:clear all strings which are on the grid.

CLEAR SELECTED:clear all selected strings on the grid.

3.4.4 AF Lists window

Flags			PS			RadioText			AFList		
	Freq	Info									
AF 1	101.0		Af list 1			Current Page					
AF 2	104.4		Af list 2			Read					
AF 3	104.5		Af list 3			Write					
AF 4			Af list 4			Write Current					
AF 5			Af list 5								
AF 6			Af list 6								
AF 7			Af list 7								
AF 8			Af list 8			Clear All					
AF 9			Af list 9			All RDS parameters					
AF 10			Af list 10			Read Coder					
AF 11			Af list 11			Program Coder					
AF 12			Af list 12			Abort					
AF 13			Af list 13								
AF 14											
AF 15											
AF 16											
AF 17											
AF 18											

The RDS encoder allows for method "A" or "B" for alternative frequencies coding.

The choice between the two methods depends on the structure of the network and the number of alternative frequencies.

There is no flag which indicates if the alternative frequencies are transmitted by method "A" or "B": the difference between the two methods is encoded in the way the frequencies are disposed into the list.

Notes:

It is not possible to compile different lists using the A and B simultaneously.

"A" method should be used only when the network has a maximum of 25 frequencies and does not differentiate regional programming.

"B" method is used when the alternative frequencies are more than 25 or when, within the same network, there is a program differentiation, such as local news or advertising, only on certain frequencies.

The lists must be compiled starting from the first and should be filled leaving no empty lists in between: any empty list will be automatically removed upon coder programming.

3.4.4.1 Editing

Flags	PS	RadioText	AFList
			Freq
			Info
AF 1		101.0	Af list 1
AF 2		104.4	Af list 2
AF 3		104.5	Af list 3
AF 4			Af list 4
AF 5			Af list 5
AF 6			Af list 6
AF 7			Af list 7
AF 8			Af list 8
AF 9			Af list 9
AF 10			Af list 10
AF 11			Af list 11
AF 12			Af list 12
AF 13			Af list 13
AF 14			
AF 15			
AF 16			
AF 17			
AF 18			

Context Menu:

- Clear list
- Sort Frequencies
- Build B List
- Insert
- Remove

Current Page:

- Read
- Write
- Write Current
- Clear All
- All RDS parameters
- Read Coder
- Program Coder
- Abort

The frequencies must be inserted starting from the first list "Af list 1", cell AF1.

Right-clicking on the list, a popup menu will appear allowing to:

Clear list: the current list will be cleared

Sort frequencies: the frequencies inserted into the current list will be sorted in ascending order

Insert: insert a new frequency at the selected cell position

Remove: remove the frequency at the selected cell position

3.4.4.2 A Method

This is the simplest method and it is indicated for all those stations which have a maximum of 25 alternative frequencies and do not provide regional - differentiated programming.

To implement this method, simply insert in AF List 1 all frequencies of the station in ascending order.

No other list must be filled.

Example:

88.1

91.3

104.1

104.5

3.4.4.3 B Method

This method is used where the number of alternative frequencies used in a network exceeds 25, or where it is required to indicate frequencies which belong to different areas which at times carry different programs.

Each transmitter and associated repeater stations broadcast the same set of different AF lists in sequence.

The number of AF lists within a network is in general identical to the number of transmitters and repeater stations in the network so as to provide a unique list for each transmitting station. In this protocol the alternative frequencies for the VHF/FM transmitters are individually addressed by transmitting the tuning frequency paired with one alternative frequency within one block.

Each list starts with the tuning frequency for which the list is valid.

All remaining pairs (up to 12) give the tuning frequency together with a valid AF.

Usually, the tuning/AF pair has to be entered in ascending order if the AF is not a regional variant of the tuning frequency, on the contrary the order has to be reversed.

If the number of AFs of a station is larger than 12, the list must be split into two or more lists. These lists are transmitted directly one after the other, and the receiver must combine the lists again.

If a transmitter frequency is used more than once within a network the respective AF lists are transmitted separately. In order to indicate that these lists with the same tuning frequency belong to different stations, the lists must be separated by AF lists of other stations.

To simplify the programming of a B list, put into the first line AF1 the main tuning frequency, then enter on the other lines (AF2 to AF13) a maximum of 12 alternative frequencies, then press the button "Build B list."

If you, in future, wish to add some new frequencies to the list, simply enter them at the bottom and press the button "Build B list again."

Flags	PS	RadioText	AFList
	Freq	Info	
AF 1	90.0		AF list 1
AF 2	104.5		AF list 2
AF 3	93.5		AF list 3
AF 4	105.2		AF list 4
AF 5	106.7		AF list 5
AF 6	104.9		AF list 6
AF 7			AF list 7
AF 8			AF list 8
AF 9			AF list 9
AF 10			AF list 10
AF 11			AF list 11
AF 12			AF list 12
AF 13			AF list 13
AF 14			
AF 15			
AF 16			
AF 17			
AF 18			

Flags	PS	RadioText	AFList
	Freq	Info	
AF 1	90.0		AF list 1
AF 2	104.5		AF list 2
AF 3	93.5		AF list 3
AF 4	105.2		AF list 4
AF 5	106.7		AF list 5
AF 6	104.9		AF list 6
AF 7			AF list 7
AF 8			AF list 8
AF 9			AF list 9
AF 10			AF list 10
AF 11			AF list 11
AF 12			AF list 12
AF 13			AF list 13
AF 14			
AF 15			
AF 16			
AF 17			
AF 18			

Current Page

Read

Write

Write Current

Clear All

All RDS parameters

Read Coder

Program Coder

Abort

The main frequency (90.0MHz) is put in the first AF cell (AF1) and all alternatives are following from AF2 to AF6.

Flags	PS	RadioText	AFList
	Freq	Info	
AF 1	90.0	Main Freq	AF list 1
AF 2	90.0	Main Freq	AF list 2
AF 3	93.5		AF list 3
AF 4	90.0	Main Freq	AF list 4
AF 5	104.5		AF list 5
AF 6	90.0	Main Freq	AF list 6
AF 7	104.9		AF list 7
AF 8	90.0	Main Freq	AF list 8
AF 9	105.2		AF list 9
AF 10	90.0	Main Freq	AF list 10
AF 11	106.7		AF list 11
AF 12			AF list 12
AF 13			AF list 13
AF 14			
AF 15			
AF 16			
AF 17			
AF 18			

Flags	PS	RadioText	AFList
	Freq	Info	
AF 1	90.0	Main Freq	AF list 1
AF 2	90.0	Main Freq	AF list 2
AF 3	93.5		AF list 3
AF 4	90.0	Main Freq	AF list 4
AF 5	104.5		AF list 5
AF 6	90.0	Main Freq	AF list 6
AF 7	104.9		AF list 7
AF 8	90.0	Main Freq	AF list 8
AF 9	105.2		AF list 9
AF 10	90.0	Main Freq	AF list 10
AF 11	106.7		AF list 11
AF 12			AF list 12
AF 13			AF list 13
AF 14			
AF 15			
AF 16			
AF 17			
AF 18			

Current Page

Read

Write

Write Current

Clear All

All RDS parameters

Read Coder

Program Coder

Abort

Right click on the list and select the "Build B List" command: the list will be compiled using "B" method.

3.4.5 Loading and saving RDS coder configuration

The remote control software allows to save and reload a complete RDS coder configuration through the File>RDS menu:

Load Configuration

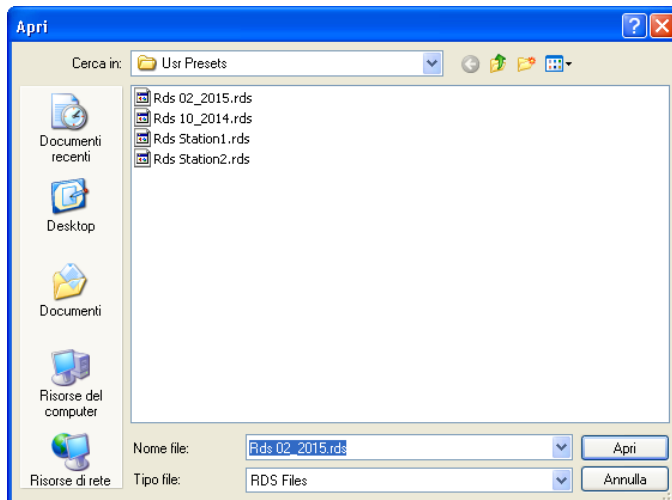
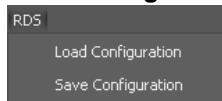

Save Configuration

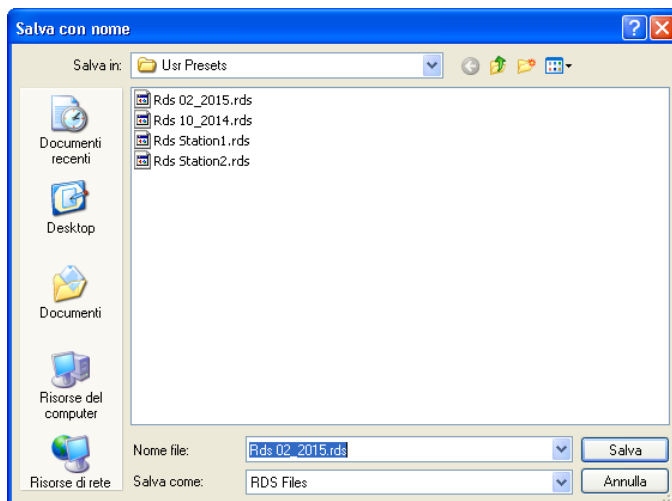
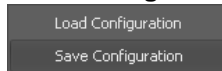

The *.rds file will contain the whole RDS encoder configuration, it can be stored as a backup or used to transfer the configuration to other devices.

3.5 Passcode setup

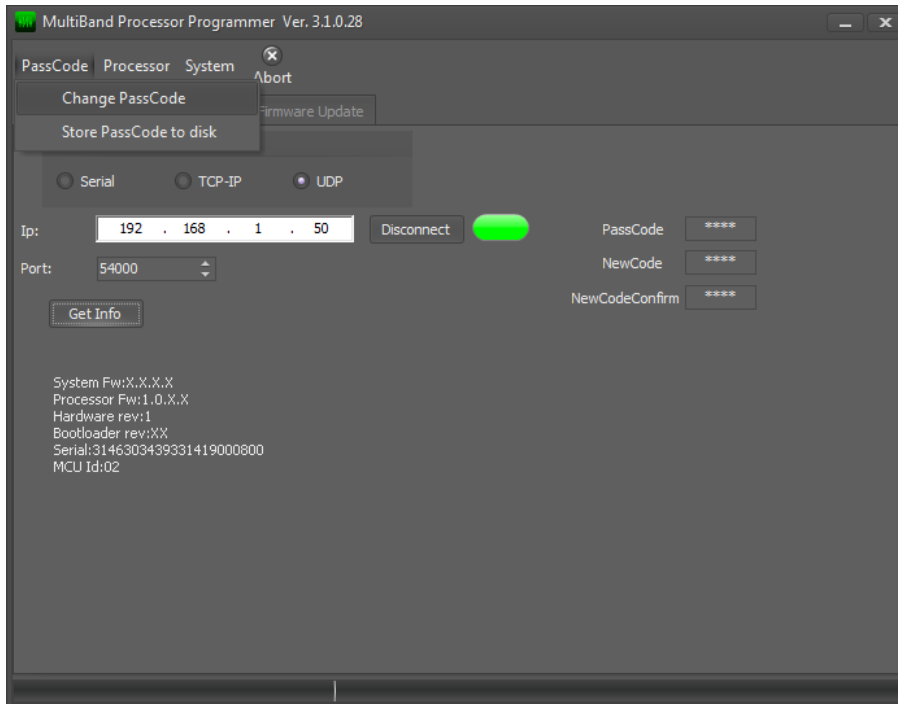

To protect the device from unauthorized operation, a security code can be set. The default code is 0000 (security disabled), but it can be changed through the following procedure:

Put the current Passcode into the PassCode edit box (0000 by default).
Put a new code into the "New Code" and, the same again, into the "New Code Confirm" editor.
Go to Menu->PassCode->**Change Passcode**

The user will be prompted for passcode change confirmation, then the passcode will be changed.

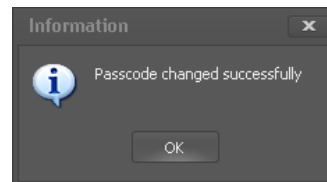
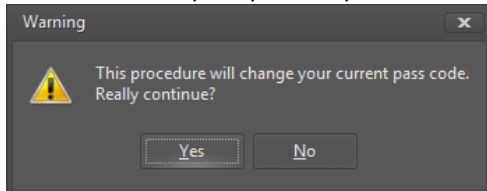

Store Password to disk: store the current passcode to not enter it each time the program is used.

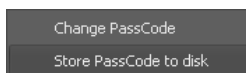
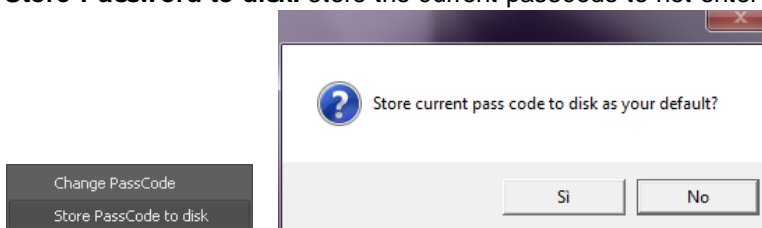

Section

RD Link

4

4 RD Link

RD-Link is a software which allows the connection of the RDS coder to the radio automation system to allow for dynamic radiotext and radiotext Plus, TA and Clock-Time to be implemented.

At the time of writing this document, the software is already compatible with several radio automation systems, but other interfaces may be included on customer request in order to extend the compatibility to other systems.

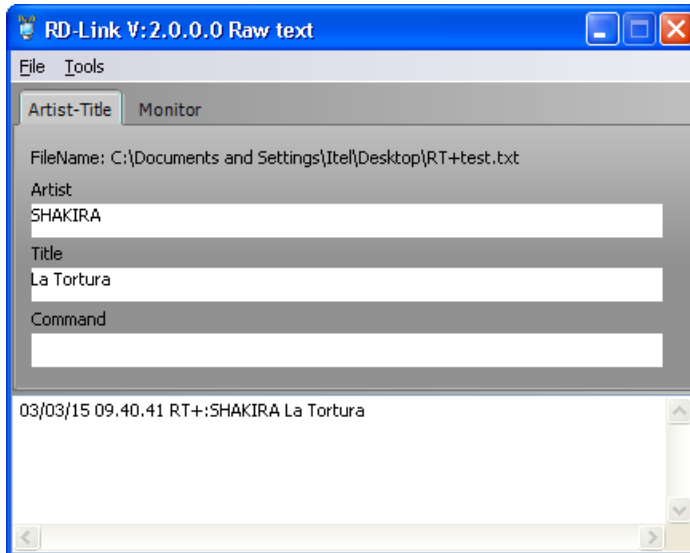

4.1 Radiotext Plus

Radio text plus is a complementary service that, united with classic radiotext, enables tagging of specific radiotext parts so that they can be isolated and used by some specialized receivers. You can then, for example, have the complete station playlist aired for the listening period.

An example of normal radiotext tagged with radiotext plus (RT+).

The normal radiotext carries the string: "SHAKIRA - La tortura"



A receiver with Radiotext Plus decoding capabilities will "know", for example, which part of the whole text is the artist's name and which is the song title.

In this case, the song title and artist's name are used to compile the playlist aired by the station we are listening.

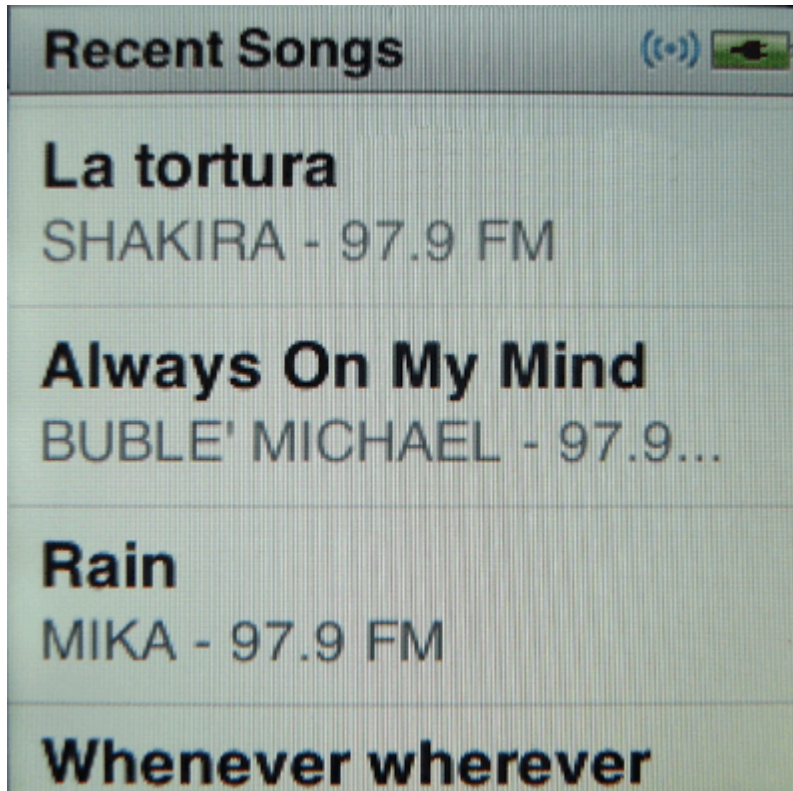

In the case below, the radiotext string is "You are listening to Shakira with La tortura Feat. Alejandro Sanz" and both normal radiotext and tagged radiotext are shown: first string is the artist name, the second is the song title, last string is the normal radiotext.



4.2 Monitor



On the **Monitor** window the dynamic PS and Radiotext strings are shown in the same way as they are being transmitted.

It is shown also the status of TA,CT, RT+ flags and scheduler.

- TA** Orange : TA flag active during traffic news on air.
 Gray: TA flag disabled
- CT** Green: transmission of Clock/Time block 4A, for remote clock visualization and
 synchronization, is enabled
 Gray: CT is disabled.

RT+ Blue: the radiotext string actually shown is tagged using radiotext plus.
Gray: Radiotext Plus is disabled.

SCHED Green:scheduler is enabled, Radiotext Plus is enabled
Red:scheduler is enabled, but actually Radiotext Plus is disabled by the scheduler
Gray: scheduler disabled, Radiotext plus tagging is controlled by the flag [Enable RT](#)

4.3 Configuration

Open configuration menu (**Tools->Configuration**), and the following window will appear:

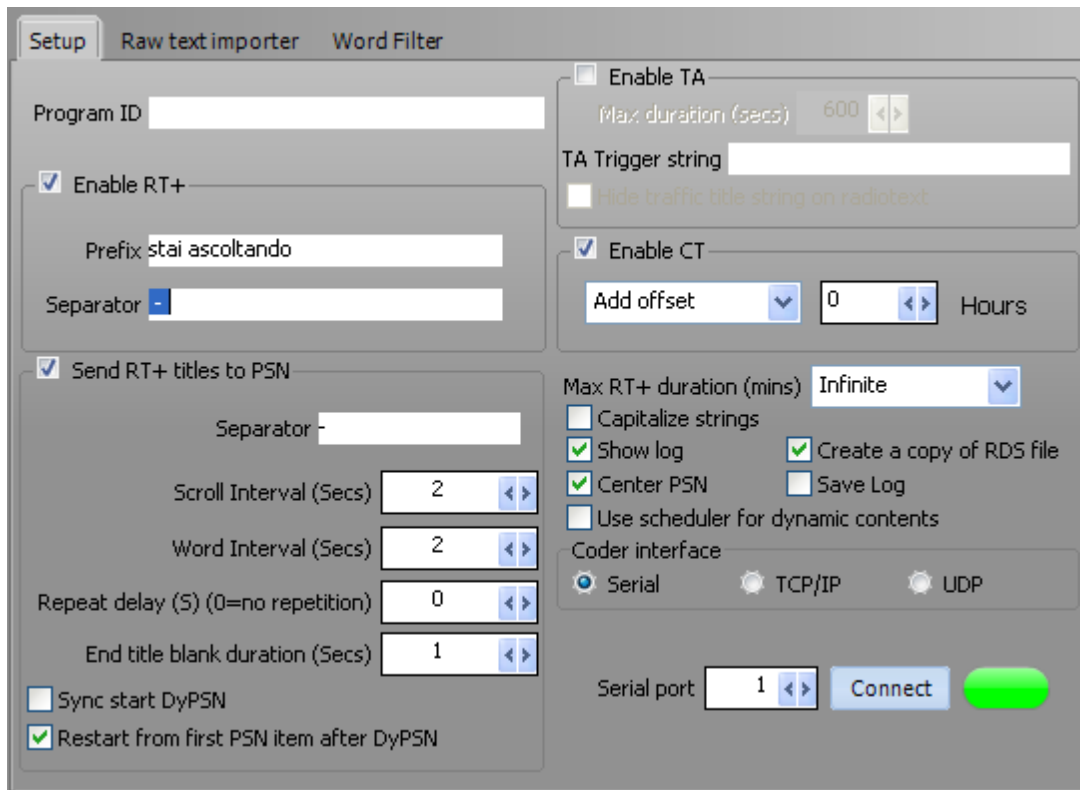

4.3.1 Setup

4.3.1.1 Program ID

It is possible to assign a name to the executable window in order to recognize it quickly, when multiple executables are running at the same time to control different coders (eg different programs belonging to the same publishing group).

4.3.1.2 Radiotext Plus and dynamic PSN

Enable RT +: Enable radiotext plus

The strings sent by radio automation system will be passed to radiotext only if this flag is enabled. You can also add a prefix and a separator to the string which will be put on-air.

Please note that the maximum length of radiotext string in block 2A, is 64 characters.

If the total length of the string, including prefix and separator, will be longer than this limit, it will be truncated automatically.

Send RT + titles to PSN: Enable sending radiotext titles on PSN.

With this function, the song titles will also be sent on the PSN (maximum length is 8 characters).

This function should be used with caution as it can cause driver distraction and in some countries is expressly prohibited. You are advised to check your local regulations before to activate it.

To limit driver distraction, single character scrolling has been reduced to a minimum, as the program tries to convey mainly whole 8 characters blocks.

Separator: separator to be inserted between title and artist. A different separator can be chosen with respect the one used for radio text.

Scroll interval (secs): scroll time interval of a single character.

All strings which will not fit 8 characters, will be displayed by scrolling one character at a time using this interval.

Word interval (secs): display time of a single word.

A word which has a length less than or equal to 8 characters, will be displayed for the time selected.

Repeat delay (secs): The title will be displayed again on the PSN , after this time (in seconds) is elapsed. If the entered value is 0, the title will be displayed once at the beginning of the new song, then the coder will send the PSN strings stored internally until the next song.

End title blank duration (secs): if set to any value other than 0, an empty PSN will be displayed for the selected duration, once the dynamic PSN is ended and before to putting on-air the internal PSN strings.

Sync start DyPSN: if enabled, it will start the dynamic PSN only at the end of the internally stored strings.

Eg internally stored strings are: "MY RADIO", "THE BEST", "IN TOWN" (loop).

Without Sync Start: "MY RADIO", "**BEATLES**", "**HELP**", "THE BEST", "IN TOWN", "MY RADIO", "THE BEST", "IN TOWN"(loop) (dynamic PS strings are bolded).

With Sync Start: "MY RADIO", "THE BEST", "IN TOWN", "**BEATLES**", "**HELP**", "MY RADIO", "THE BEST", "IN TOWN"(loop) (dynamic PS strings are bolded).

Restart from first PSN item after DyPs: if enabled, after a dynamic PSN is transmitted, it will restart the display of internal strings from the beginning.

Eg internally stored strings are: "MY RADIO", "THE BEST", "IN TOWN" (loop).

Without restarting: "MY RADIO", "**BEATLES**", "**HELP**", "THE BEST", "IN TOWN", "MY RADIO", "THE BEST", "IN TOWN"(loop) (dynamic PS strings are bolded).

With restarting: "MY RADIO", "**BEATLES**", "**HELP**", "MY RADIO", "THE BEST", "IN TOWN"(loop) (dynamic PS strings are bolded).

4.3.1.3 TA - Clock time

Enable TA: the TA flag will be switched on during traffic news.

Max duration: maximum traffic news duration. Once this time is elapsed, the TA flag, if it was previously set on, will be automatically switched off.

TA Trigger string: it is the name, as passed to the program by the radio automation system, of the traffic news audio file. If traffic news are live, this could be the name of the file used as traffic news liner. The name is case insensitive.

Hide traffic title string on radiotext: if enabled, it will not send the string associated with the traffic news file to radiotext or PSN.

Enable CT: enable sending CT (clock time).

Enabling this function, it will be sent the 4A block for radio alarm clocks synchronization and date-time visualization.

As the PC system clock will be used, it is recommended to keep the system clock synchronized using any time server.

The 4A block transmission will be suspended when PC is shut off or the PC-Coder communication is broken.

Add offset: offset for the time currently sent.

4.3.1.4 Communication interface and additional settings

Max RT Duration: maximum radiotext duration.

This control sets the maximum time for the same Radiotext Plus string visualization. If this period is exceeded, the coder will start to send the internally stored RT strings, returning to dynamic RT+ once a new string is received.

Show log: show program activity log.

Center PSN: auto center the strings displayed on PSN, if they are shorter than 8 characters.

Use scheduler for dynamic contents: enable scheduler for dynamic radiotext plus and PSN activation, if they are supposed to be active only on some week days or at a specified time,

Create a copy of RDS file: creates an identical copy of the title file written by the automation system to be read by other applications (eg: streaming encoder).

Save log: save a daily program activity log on a file eg: "log_18-06-2014.txt"

Coder interface: communication interface selection, RS232, TCP/IP or UDP.

4.3.2 Raw Text Importer

Raw text importer allows to read plain text files generated by the radio automation system.

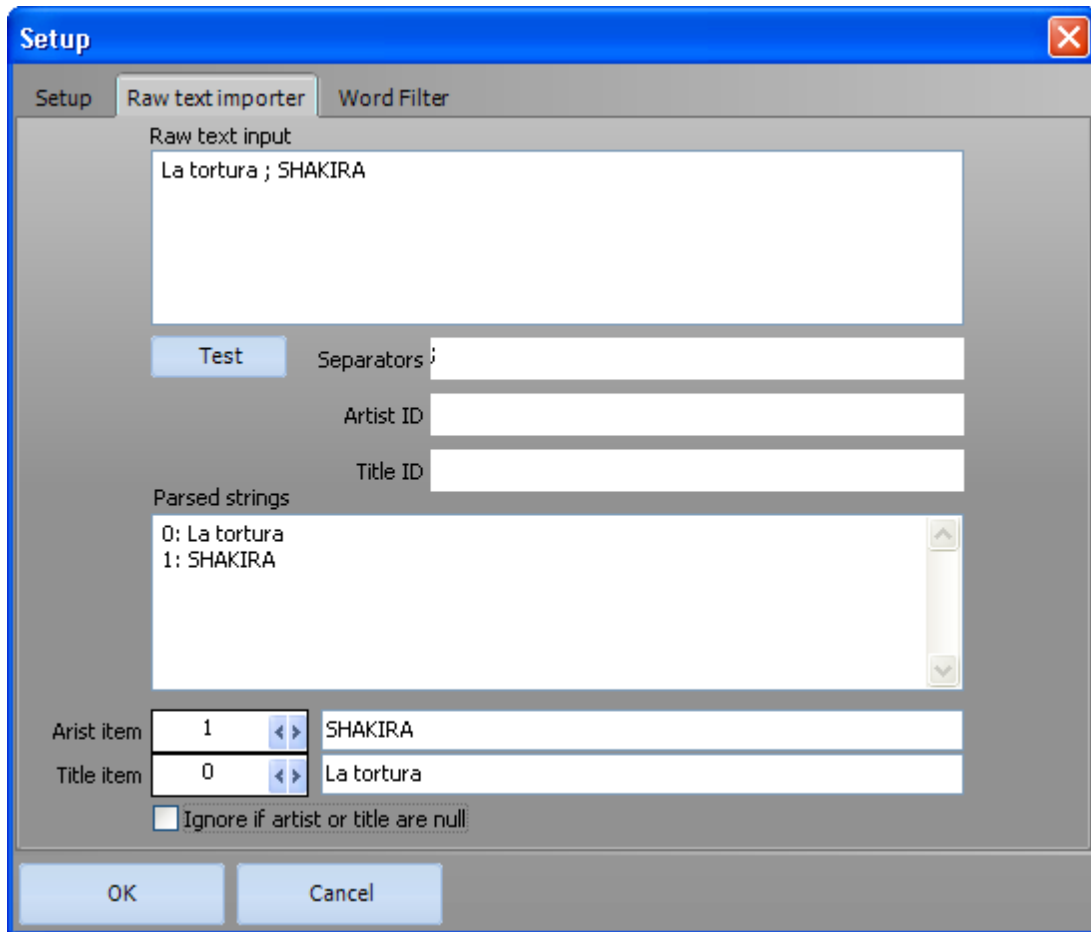

The contents of the currently selected file (from the main window menu **File-> Raw TextFile**) is displayed in the **Raw Text Input**.

The artist and title fields may be separated in two ways:

using separators: the strings read from the file will be divided using the characters entered in the "Separators" editor.

In the above example, the input string "SHAKIRA;La tortura" is divided, using the separator ";".

This will produce two output lines (line 0:La tortura, line 1: SHAKIRA).

Then, using the controls "Artist item" and "Title item", set which line must be used as title and which one as the artist name.

using identifiers eventually included in the raw file: if the raw file was already marked with labels such as:

CurrArtist = Michael Jackson

CurrTitle = Thriller

you can simply enter in the editors "Artist ID" and "Title ID" the two identifiers "CurrArtist =" and "CurrTitle =" (without quotes).

The program will then automatically isolate strings related to artist name and song title.

4.4 Scheduler

The dynamic content scheduler (**menu Tools->Scheduler**) allows to activate the Radiotext Plus and dynamic PSN only in predetermined time intervals.

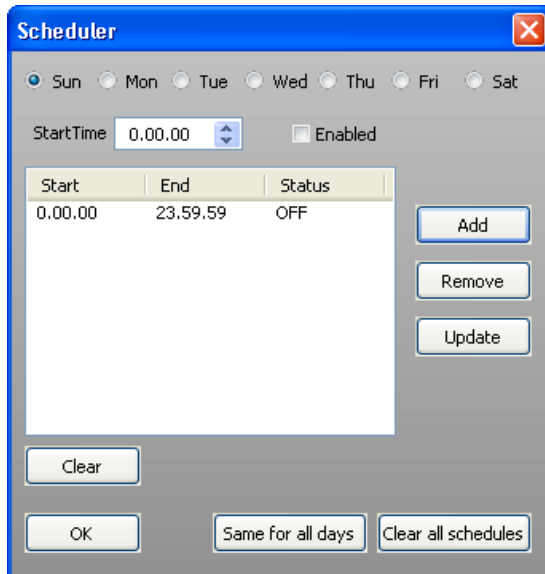

For example, we want to use dynamic RT+ and PSN only from 8.00 to 12.00 and from 18.00 to 23.00 every day except on Sundays where it will be active for the entire day.

So an event must be created, scheduled for 8:00 am (set into "**Start Time**" box), having "**Enabled**" status checked.

Pressing the "**Add**" the button, the event will be added to the events list.

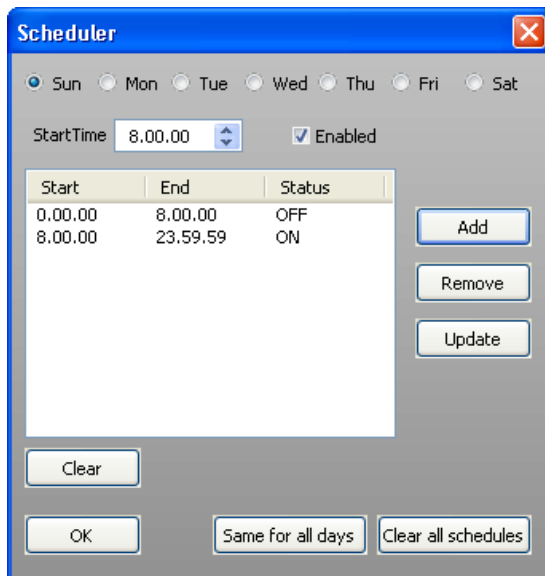

We have that the dynamic content will be disabled from 00.00 to 8.00 then, for the event we created, from 8.00 onwards it will be enabled.

Now the dynamic content disabling event should be added: put 12:00 into the "**StartTime**" box, uncheck the "**Enabled**" checkbox and push "**Add**" button.

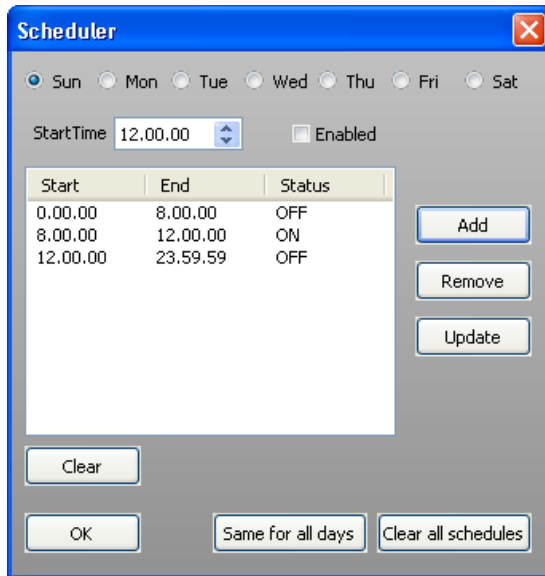

The dynamic content has to be re-enabled from 18:00 to 23:00, so one enabling event has to be added at 18:00 and a disabling event at 23:00. In the following picture is represented the complete programming.

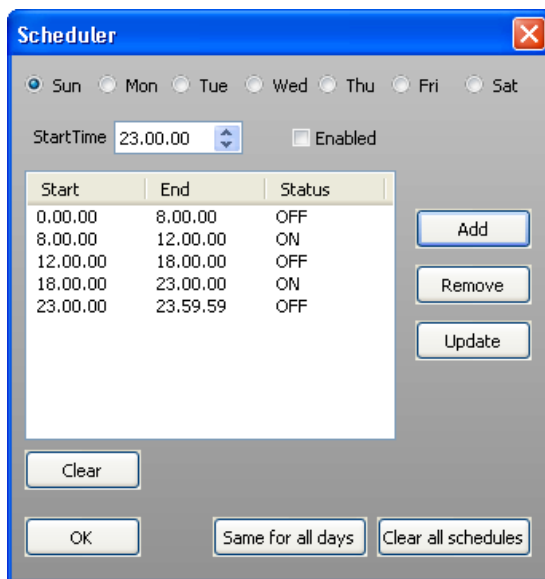

Summarizing: firstly the dynamic content enabling was added at 8:00hr, then the disabling event at 12:00hr, the re-enabling at 18:00hr and the disabling at 23:00hr. Since this scheduling will be the same for almost the whole week, it can be simply copied to the other days, pressing the **"Same for all days"** button.

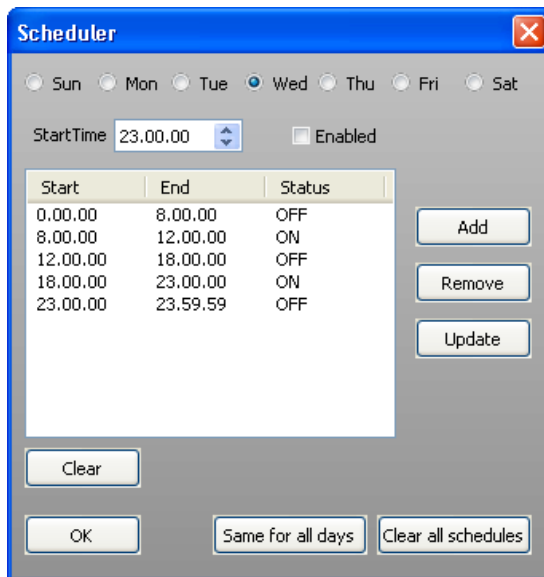

Once copied, it can be verified that, changing the week day selection at the top of the window, the scheduling is the same for all days.

Done this, you will then modify the Sunday scheduling only, where the dynamic content will be enabled for the whole day.

Select the week day, on the top of the window, "**Sun**"

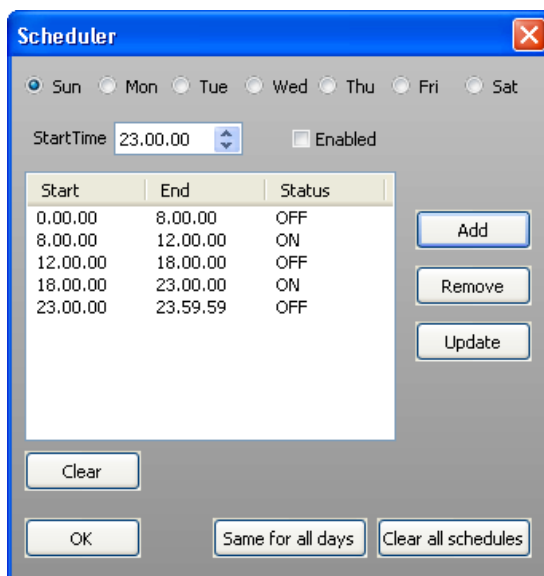

Press the "**Clear button**" to delete all scheduler entries for the current day.

Once all entries have been deleted, just add an event starting at 00:00, with "**Enabled**" checkbox checked to enable the dynamic content .

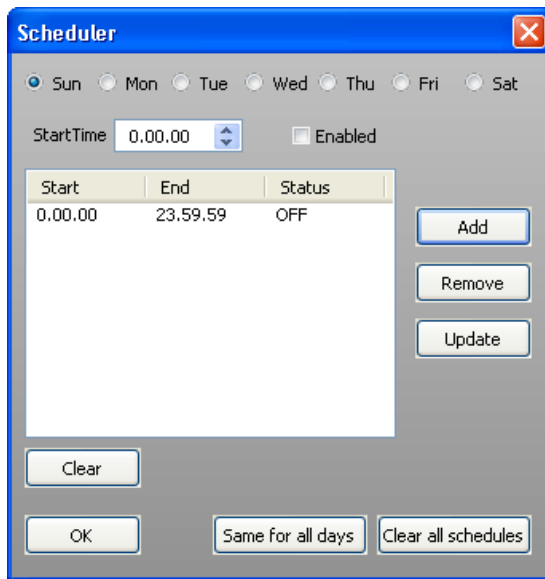

Programming is completed. Press "**OK**" button to save and exit from the current window.

Follows a short description of the other controls on the window:

Remove: removes the currently selected entry

Update: updates the currently selected entry with new time and/or status informations.

Clear all schedules: deletes all entries over all days.

Section

Streaming audio module

5

5 Streaming audio module

The module adds audio streaming decoding capabilities for receiving streaming HLS / MP3 / AAC + shoutcast servers by HTTP/HTTPS using TCP / IP connectivity. The module also allows playback of audio files from an USB key.

The audio output is transferred in digital format to audio processor / stereo encoder, thus achieving the highest audio quality.

5.1 Quick setup

The default IP address is **192.168.1.100**.

By an internet browser, open page: <http://192.168.1.100>.

Make login with:

Username: admin

Password: admin

Go to section "STREAMING SETTINGS" and set one or more streams to receive audio. Save config by "SAVE CONFIGURATION".

If needed, change module network settings by NETWORK SETTINGS page. Save config by "SAVE CONFIGURATION".

5.2 Audio decoder

Connect the device to the LAN, open a web browser on a PC from which you can access the device, and type <http://192.168.1.100> into the browser's address bar.

The audio module's internal web server will load the default login page.

By frontal panel of the machine, it's possible to change it. Refer to Ethernet Setup chapter.

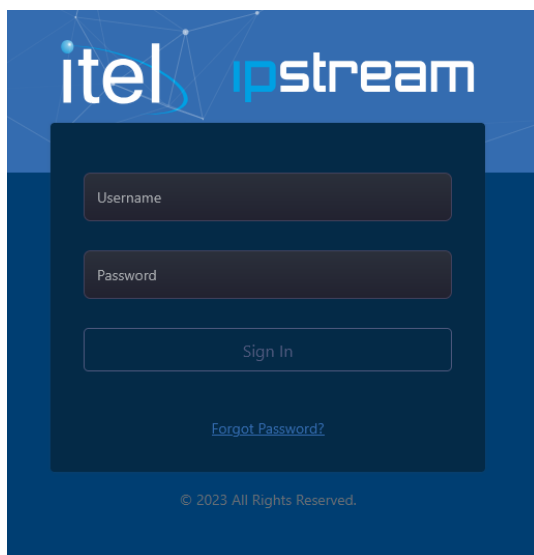

Default login username/password is admin/admin.

In case of change password and subsequent forgot, it's possible to recover by the link FORGOT PASSWORD:

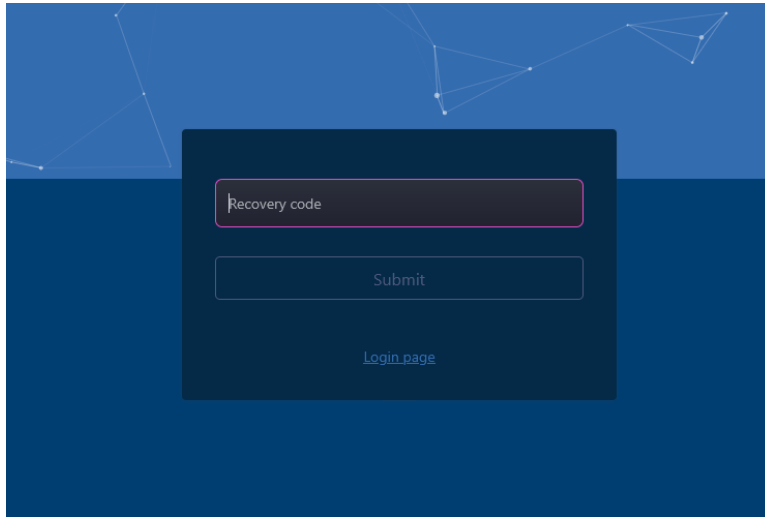
A screenshot of a web application interface for password recovery. The background is a dark blue gradient with a faint constellation pattern. A dark grey modal box is centered on the screen. Inside the modal, there is a text input field labeled "Recovery code" with a red border. Below the input field is a "Submit" button. At the bottom of the modal, there is a blue link labeled "Login page".

Enter recovery code 90355447 then click on SUBMIT.

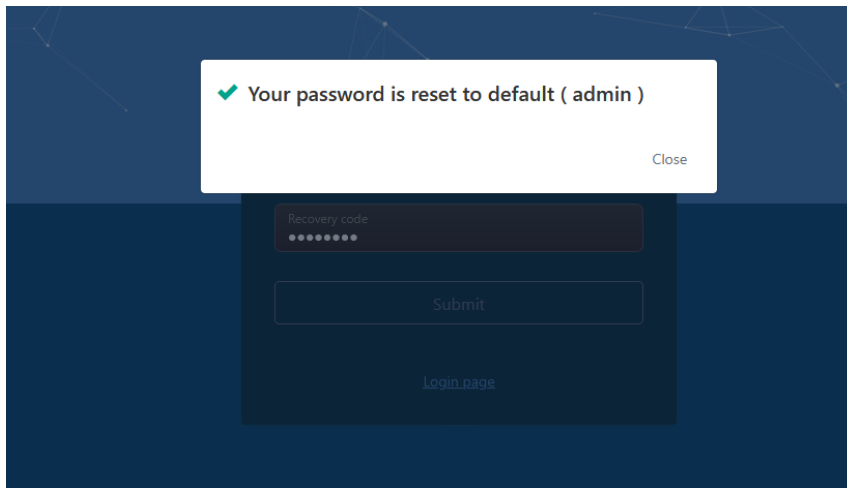
A screenshot of the same web application interface. A white notification box with a green checkmark icon is displayed at the top, containing the text "Your password is reset to default (admin)" and a "Close" button. Below the notification, the dark grey modal box from the previous screenshot is visible, but the "Recovery code" input field now contains seven dots, indicating that the code has been entered. The "Submit" button and "Login page" link are still present.

Once you have successfully logged in, you will have access to all the module settings and the STATUS page will appear:

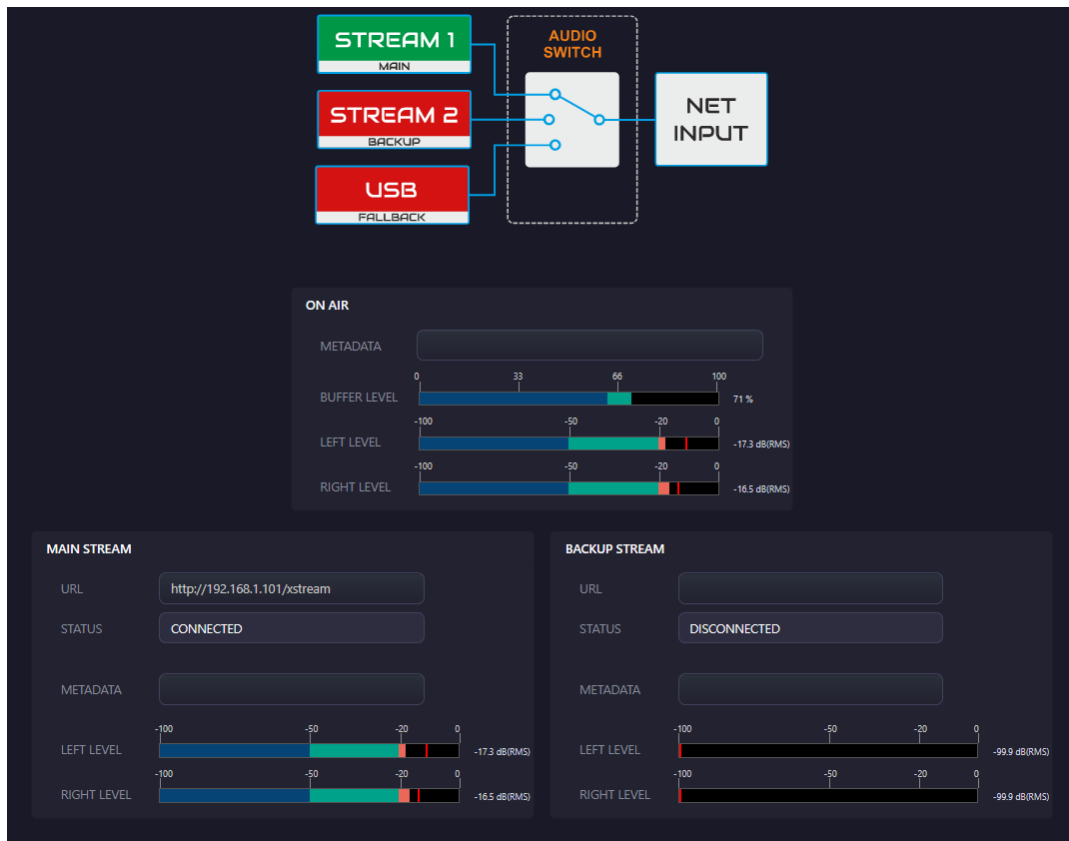

Go to menu "Streaming settings" and set one or more URLs as streaming audio source(s).

It's possible to configure also the USB drive fallback, that will be on air in case of no streams are available.

Save current setup by "Save configuration" button.

MAIN STREAM

BACKUP STREAM

METADATA ROUTER SETTINGS

Redirect MetaData to RadioText

METADATA STRING FIELD SEPARATOR

Field 1 means

Field 2 means

Field 3 means

Field 4 means

Field 5 means

Field 6 means

USB FALLBACK SETTINGS

Enable USB Fallback

Interleave SONGS/JINGLES

Every SONGS Play JINGLES

Available USB files

- MIKA - Grace kelly.mp3
- MIKA - Happy ending.mp3
- MIKA - Kick Ass.mp3
- MIKA - Love today.mp3
- MIKA - Rain.mp3
- MIKA - Relax.mp3
- MIKA - We Are Golden.mp3
- Mousse T feat. Suzie & Jovanotti - All nite long (D.I.S.C.O).mp3
- RIHANNA - Don't Stop The Music.mp3
- RIHANNA - Rude boy.mp3
- RIHANNA - Umbrella.mp3

The streaming audio decoder module allows reception of MP3/AAC+/HLS/FLAC/WAV streams from Shoutcast servers via TCP/IP connectivity. The module also allows playback of audio files from USB flash drives.

To enable the fallback feature from an USB drive, insert a FAT32-formatted USB flash drive containing audio files in MP3, AAC, FLAC, or WAV format. Detailed settings are described next to the same configuration pages in the integrated web server.

Once the module is configured, adjust the audio processor and select the "NetAudio" audio input. You should be able to hear the audio stream received by the module.

Adjust the audio input level of the "NetAudio" input if necessary. If you intend to use any audio processing during streaming playback, you can omit this setting as the processor will automatically adjust the level. The preset for the network input can be selected in the next window, once the NetAudio input has been selected.

If you want to use more than one audio source for use with the internal automatic switching (audio fallback), select it and then set the corresponding preset. Finally, set the automatic switching of the selected inputs.

5.2.1 Status

The Status section displays information about the connection status of your streams, audio levels and the source currently playing.

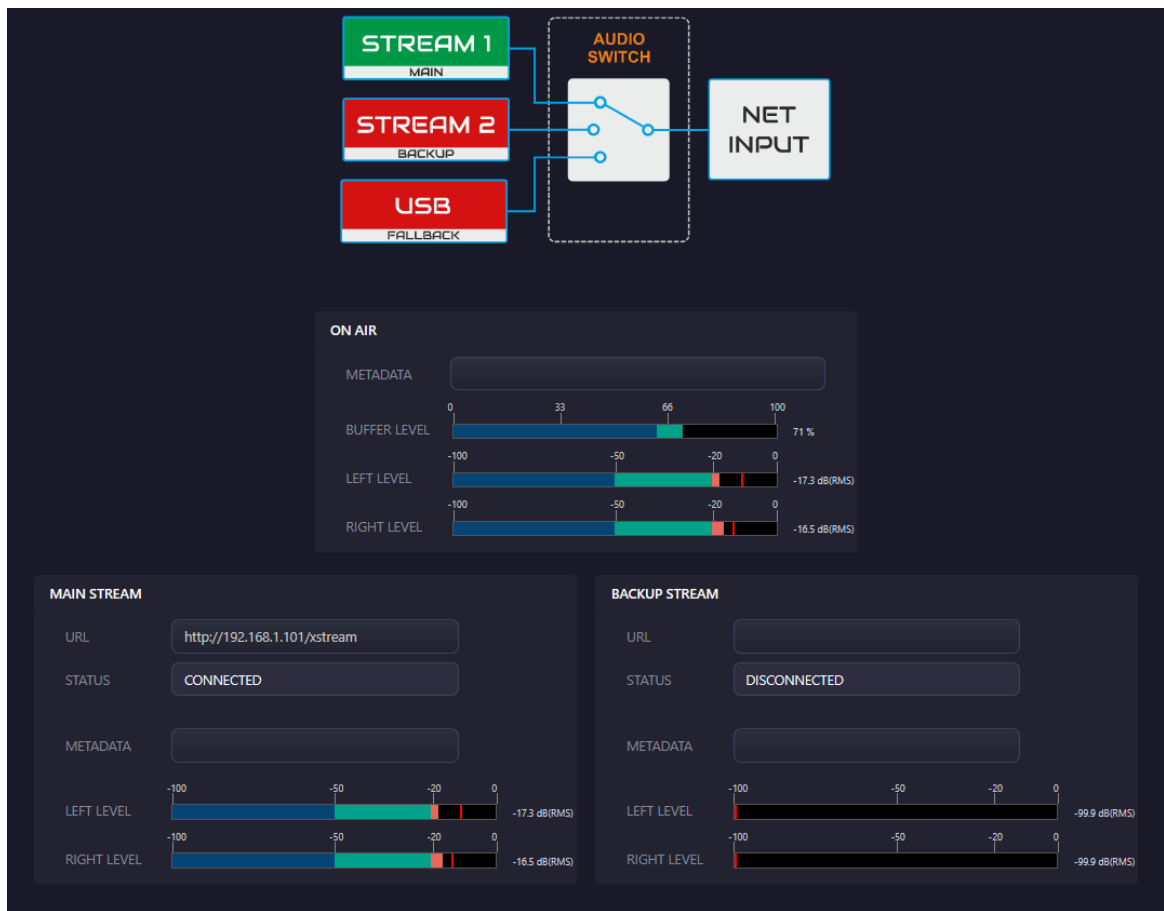

The synoptic provides a real-time representation of the status of the various sources and the audio changeover.

The colors of the source boxes represent the various states:

- GREEN: Stream connected
- YELLOW: Stream connected but with audio (on at least one channel) below the silence threshold
- RED: Source not connected/not available
- GRAY: Source disabled (USB only)

Various information about the source being broadcast is also displayed, which can be the main stream, backup stream, or USB fallback:

- BUFFER LEVEL: Audio buffer level, expressed as a percentage
- METADATA: The metadata string extracted from the stream (or the ID3 tag/file name in the case of USB fallback)
- LEFT/RIGHT LEVEL: Audio level, in dB. The solid bar represents the RMS value of the audio, while the red thin bar represents the peak value.

5.2.2 Streaming settings

The following section allows you to set one or more URLs from which to receive audio streaming. It's possible to configure also the USB drive fallback, that will be on air in case of no streams are available.

Main Stream: URL of main streaming source

Backup Stream: URL of backup streaming source

Redirect Metadata to RadioText: Transmits the metadata content carried by the stream in RadioText to the RDS encoder (if option is present and enabled). See the dedicated section for RDS encoder management.

It also allows metadata formatting to be interpreted so that RT+ tags are correctly populated.

You can set the separator string for the various fields (the tilde ~ in the image) and their meaning.

For example, with reference to the image, a metadata such as

"MIKA~Grace Kelly"

would extract the artist "MIKA" and the song "Grace Kelly," thus correctly populating the RT and RT+ with the relevant tags.

If no separator is specified, or if it is incorrect, the entire metadata string will be forwarded to RadioText without further modification or processing.

Enable USB Fallback: Enable the USB audio fallback function that will be on-air in case of no stream will be marked as valid for broadcast (by audio threshold)

Interleave SONGS/JINGLES: Interleave, every X songs, Y jingles.

For USB backup to work properly, insert a FAT32 or NTFS formatted data medium. It must have the following folder structure:

- ROOT
 - songs
 - jingles

If they aren't present, they will be automatically created by the device. Populate the "songs" folder with songs and the "jingles" folder with jingles.

Everything is also accessible remotely via FTP, using the same login (username/password) used for web login.

The default port is 54021. Can be changed in the NETWORK SETTINGS menu.

Save Configuration: Save current setup.

5.2.3 Network settings

Page used for modify the parameter of IP, SMTP, NTP.

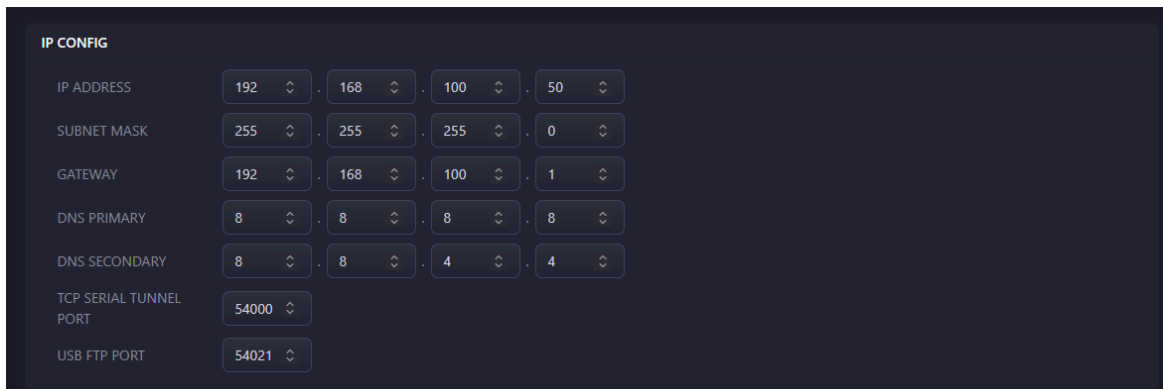

The screenshot shows the 'IP CONFIG' menu with the following settings:

Parameter	Value
IP ADDRESS	192 . 168 . 100 . 50
SUBNET MASK	255 . 255 . 255 . 0
GATEWAY	192 . 168 . 100 . 1
DNS PRIMARY	8 . 8 . 8 . 8
DNS SECONDARY	8 . 8 . 4 . 4
TCP SERIAL TUNNEL PORT	54000
USB FTP PORT	54021

IP CONFIG:

IP Address: Ip Address assigned to module, default 192.168.1.100

Subnet Mask: Subnet mask assigned to module , default 255.255.255.0

Gateway: Ip address of GTW, default 192.168.1.254

DNS Primary: Primary DNS resolver, default 8.8.8.8

DNS Secondary: Secondary DNS resolver, default 8.8.4.4

TCP serial tunnel port: Port used for remote connection with PROCESSOR PROGRAMMER Application for Windows Os.

USB FTP Port: Port used for FTP connection for upload songs and jingles remotely into USB drive. Use same login (user/pass) as web interface.

SMTP CONFIGURATION

SMTP Server: SMTP Port: 465

Authentication: NO

Username: email@itel.it Password:

Require SSL: NO

Sender Email Address:

Recipient 1 Email:

Recipient 2 Email:

Recipient 3 Email:

SMTP CONFIG:

Used to configure the sending of alarm emails. It allows you to set up a sending account and up to three recipients.

SMTP server: Outgoing mail server address

SMTP port: Outgoing mail server port

Authentication: Enable/Disable outgoing mail server auth

Username/Password: Use only with authentication enabled.

Require SSL: Enable/Disable SSL cipher

Sender email address: Email address of the account used for send

Recipient (N) Email: Alarm mail recipients

NTP

NTP 1 ADDRESS: 0.europe.pool.ntp.org

NTP 2 ADDRESS: ntp1.inrim.it

NTP 3 ADDRESS: ntp2.inrim.it

NTP CONFIG:

Used for set up to 3 NTP servers.

Default:

- time.nist.gov
- ntp1.inrim.it
- ntp2.inrim.it

5.2.4 System settings

It is possible to change the StationID, the password for login from WEB and FTP and other parameters related to the audio changeover.

The screenshot shows a configuration interface with the following fields and values:

- STATION ID: Test10050Dpro6
- SYSTEM PASSWORD: [masked] Show
- Volume: 0 dB
- Buffer(s): 10
- Timezone: Europe/Rome
- Changeover switch time(s): 30
- Changeover switchback time(s): 30
- Silence threshold: -50 dB

A green button labeled "SAVE CONFIGURATION" is located at the bottom left of the settings area.

Station ID: Device ID. This is a character label provided to the user to identify the device. It is also displayed on the front panel of the machine, it cannot be used for RDS.

System password: Password for web/ftp login.

Volume: Range +-5 dB, allows you to amplify or attenuate the audio coming from the stream/USB before being fed into the device's NetAudio input.

Buffer: In seconds, range 5-50, allows you to set the audio buffer duration for streams. A larger audio buffer is more resilient to poor network conditions, but introduces greater delay.

Timezone: Set to have the correct time zone on the machine and therefore have the alarm and event logs correctly placed in time.

Changeover switch time: Timeout used when "silence" a source: after at least this amount of time has elapsed with the source declared silent, the changeover will switch to the source with the immediately lower priority.

Changeover switchback time: Timeout used when retrieving a source: after at least this amount of time has elapsed with the declared source playing, the changeover will switch to the source with the next highest priority.

Silence threshold: RMS audio level threshold, in dB. If both channels are above this value, the source will be declared as good. If at least one channel is below this value, the source will be declared muted.

5.2.5 Alarm settings

This page allows you to configure the alarm reporting mode. You can choose whether or not to enable monitoring for a specific alarm, whether or not to send TRAP/EMAILS and a timeout so that only alarms that last longer than the alarm are notified.

	Enable ALARM	SNMP TRAP	DELAY TRAP
Main stream disconnect	YES	YES	10
Backup stream disconnect	YES	YES	10
Main source not available	NO	YES	10

SAVE CONFIGURATION

Enable Alarm: Enable/Disable the control of the condition that triggers that alarm

SNMP TRAP: Enable/disable sending of TRAPS and EMAILS in case of alarm/de-alarm

DELAY TRAP: Timeout in seconds. Only alarms that last longer than this are reported. The alarm resolution event is also reported only if it lasts at least the timeout period.

LISTA ALLARMI:

Main stream disconnect: Get notified when the main stream is unavailable (disconnected or audio below threshold)

Main stream disconnect: Get notified when the backup stream is unavailable (disconnected or audio below threshold)

Main source not available: It is notified when the machine, originally on its main input (Analog input or Digital input), automatically switches to NetAudio. Useful for understanding that the device has switched to streaming from the backbone.

5.2.6 Active alarms

Shows the machine active alarm and the timestamp of start.

Type	Start
BACKUP STREAM DISCONNECTION	07-07-2025 14:57:35

Copy: Copies all table content

Print: Enables a view that is optimized for printing.

5.2.7 Alarm logs

This page lists the alarm history (HISTORY ALARMS) and the system event log (SYS LOGS). For each alarm, the type, alarm start date/time, and alarm end date/time are recorded.

The screenshot displays two panels: 'HISTORY ALARMS' and 'SYS LOGS'. The 'HISTORY ALARMS' panel includes a 'Reset Alarms' button and three action buttons: 'Copy', 'Print', and 'CSV'. Below these buttons, it indicates 'Showing 1 to 2 of 2 entries'. A table lists the following entries:

Type	Start	End
MAIN STREAM DISCONNECTION	07-07-2025 11:20:45	07-07-2025 11:20:46
BACKUP STREAM DISCONNECTION	07-07-2025 11:20:45	07-07-2025 11:20:48

The 'SYS LOGS' panel shows a list of system events:

- 2025-07-07 11:20:45: Streamer switch to MAIN Stream
- 2025-07-07 11:20:44: New Streaming setting saved
- 2025-07-07 10:33:32: System Started

Copy: Copies all table content

Print: Enables a view that is optimized for printing

CSV: Format the table content in a CSV file and download them

Reset Alarms: Reset all history alarms and sys logs.

5.2.8 SNMP settings

The various SNMP agent configuration items are present. Up to 3 TRAP recipients can be configured.

The screenshot shows the 'SNMP CONFIGURATION' section with two main parts: 'TRAP CONFIGURATION' and 'SNMP CONFIGURATION'. The 'TRAP CONFIGURATION' section includes three rows for TRAP 1, TRAP 2, and TRAP 3, each with fields for ADDRESS, Port, and Community. The 'SNMP CONFIGURATION' section includes fields for Public Community, Private Community, and Port.

TRAP CONFIGURATION:

- TRAP 1 ADDRESS: 192 . 168 . 100 . 199
- TRAP 1 Port: 162
- TRAP 1 Community: public
- TRAP 2 ADDRESS: 0 . 0 . 0 . 0
- TRAP 2 Port: 1620
- TRAP 2 Community: publiccc
- TRAP 3 ADDRESS: 0 . 0 . 0 . 0
- TRAP 3 Port: 16200
- TRAP 3 Community: publiccccc

SNMP CONFIGURATION:

- Public Community: public
- Private Community: private
- Port: 161

A 'SAVE CONFIGURATION' button is located at the bottom of the configuration area.

Trap (N) Address: IP address of TRAP recipient

Trap (N) Port: Port used for trap send

Trap (N) Community: Community used by the recipient to validate the TRAP

Public community: Password for Read-Only objects

Private community: Password for Read-Write objects

Port: UDP port used by SNMP agent.

5.2.9 Split control

Allows you to manually set and control the device's splitting capabilities

DSP Actual Input: Indicates the selected input of the machine(Analog - Digital - NET)

Split Status: Indicates if the machine is on splitting mode or not

Split Timeout: Timeout to return the device in idle mode if the split command is not repeated within this time frame.

Disable Split: Returns the device to the default input and enables changeover to IP Stream

Split to Analog Input: Splits the device to Analog Input

Split to Digital Input: Splits the device to Digital Input.

Split to Net - Auto: Splits the device to Network Input and enables changeover to IP Stream

Split to Net - Main: Splits the device to Network Input and forces IP Stream changeover to Main

Split to Net - Backup: Splits the device to Network Input and forces IP Stream changeover to Backup

Split to Net - USB: Splits the device to Network Input and forces IP Stream changeover to USB.

You can control splitting by sending strings, in plain text, over the same TCP control port used by the application.

Command list:

- Return To main (Disable Split) -> [AB010002]
- Split to Analog Input -> [AB010103]
- Split to Digital Input -> [AB010200]
- Split to Net AUTO Input -> [AB010301]
- Split to Net MAIN Input -> [ABFF0100]
- Split to Net BACKUP Input -> [ABFF0200]
- Split to NET USB Input -> [ABFF0300]

5.2.10 FW upgrade

Used to read the SW releases of the various components of the machine, the Backup/Restore of the configuration and the FW update.

The screenshot displays the 'FW UPGRADE' interface. It features a dark background with white text and buttons. The top section, titled 'FW UPGRADE', contains a grid of system information: HW Rev (MX6UL_0), UI Version (1.1.1), BE Version (1.0.7), Mac Address (9C:53:CD:03:AE:9D), Firmware Version (1.1.1), APPL/ENG Version (1.1.13), DSP HW Revision (02), DSP Bootloader Version (82), DSP Firmware Version (Sys:3.2.2.1-Proc:1.0.2.0), and DSP Serial ID (3757333730390808001300-2). Below this is the 'Firmware file' section with a 'Choose file' input, a 'Browse' button, and a 'Start FW Update' button. The 'Configuration file (Data.dat)' section has a 'Choose file' input, a 'Browse' button, and 'Restore configuration' and 'Backup configuration' buttons. At the bottom, there are 'Download MIB' and 'Reboot' buttons.

Firmware File: Select the IPK file to update the module. Start the procedure with Start FW Update. This process may take up to 5 minutes; please wait until it is complete.

Configuration File: Allows you to save the current configuration (Backup) or restore it (Restore).

MIB Download: Direct download of the .MIB file for remote streamer management.

Reboot: Reboots the IPStream module (not the entire machine).